



RIRS 400-700 H EKO 3.0

EN MOUNTING AND INSTALLATION INSTRUCTION



1. CONTENTS

1. CONTENTS	2
2. SYMBOLS AND MARKING	3
3. SAFETY INSTRUCTIONS AND PRECAUTIONS	4
4. INFORMATION ABOUT THE PRODUCT	5
4.1. DESCRIPTION	5
4.2. DIMENSIONS AND WEIGHT	5
4.3. TECHNICAL DATA	6
4.4. OPERATING CONDITIONS	7
4.5. STANDARD PACKAGE OF COMPONENTS	7
4.6. DESCRIPTION OF COMPONENTS	7
5. INSTALLATION	8
5.1. RECEPTION OF GOODS	8
5.2. TRANSPORTATION AND STORAGE	8
5.3. UNPACKING	8
5.4. PIPING AND INSTRUMENTATION DIAGRAM	9
5.5. MOUNTING	10
5.5.1. UNIT PLACING AND MOUNTING POSITIONING REQUIREMENTS	11
5.5.2. FLOOR MOUNTING	11
5.6. CONNECTION OF THE AIR DUCT	11
5.7. CONNECTION OF THE UNIT TO THE ELECTRIC NETWORK	12
5.8. START-UP RECOMMENDATIONS	12
5.8.1. SYSTEM PROTECTION	12
5.8.2. PRE START-UP RECOMMENDATIONS OF THE UNIT (IN THE PRESENCE OF THE END-USER)	12
6. MAINTENANCE	13
6.1. SAFETY INSTRUCTION	13
6.2. GENERAL RECOMMENDATIONS FOR VENTILATION SYSTEM MAINTENANCE	13
6.3. COVER OPENING	13
6.4. FILTERS MAINTENANCE	14
6.5. ROTOR MAINTENANCE	14
6.6. FANS MAINTENANCE	14
6.7. HEATER MAINTENANCE	15
6.8. CONTROL BOARD MAINTENANCE	15
7. CONTROL	16
7.1. DEVICE CONTROL	16
7.2. DEVICE FUNCTIONS	16
8. CONNECTION OF ACCESSORIES	17
8.1. FIRE PROTECTION SIGNAL INPUT (FIRE PROTECTION INPUT (NC))	17
8.1.1. PRV CONTROL BOARD	17
8.1.2. MCB CONTROL BOARD	17
8.2. EXTERNAL CO ₂ /PRESSURE SENSORS	17
8.2.1. PRV CONTROL BOARD	17
8.2.2. MCB CONTROL BOARD	17
8.3. ROOM CO ₂ TRANSMITTER INSTALLATION RECOMMENDATION	18
8.4. CO ₂ CONCENTRATION ACCORDING TO PETTENKOFER LIMIT	18
8.5. CONNECTION OF SUPPLY AND EXTRACT AIR DAMPERS	18
8.5.1. PRV CONTROL BOARD	18
8.5.2. MCB CONTROL BOARD	19
8.6. CONNECTION OF REMOTE CONTROL PANEL OR MODBUS	19
8.6.1. PRV CONTROL BOARD	19
8.6.2. MCB CONTROL BOARD	20
8.6.3. "MCB TOOL" PROGRAM DESCRIPTION	20
8.7. WATER HEATER CIRCULATION PUMP AND VALVE ACTUATOR	22
8.8. RECOMMENDED SCHEME FOR CONNECTION OF INTERNAL AND EXTERNAL COMPONENTS	23
9. POSSIBLE FAULTS AND TROUBLESHOOTING	28
10.ECODESIGN DATA TABLE	29
11.DECLARATION OF CONFORMITY	30
12.WARRANTY	31
12.1. LIMITED WARRANTY COUPON	31

2. SYMBOLS AND MARKING



Warning – pay attention



Additional information

Apply the technical label on the unit (in an easily accessible location) or on the dashed location of the technical manual to keep the important information about the unit.

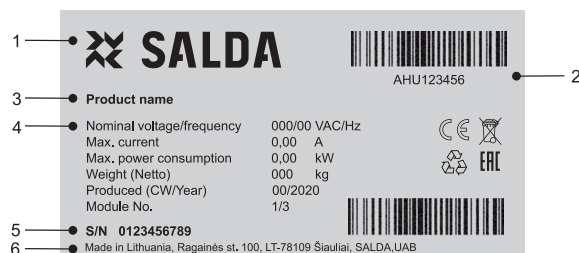

Figure 2.1 Technical label

1 - Logo; 2 - Product code (SKU); 3 - Product name; 4 - Technical data; 5 - Serial number; 6 - Production place.



Figure 2.2 Indication for duct connection.

ODA - outdoor air; SUP - supply air; ETA - extract air; EHA - exhaust air.

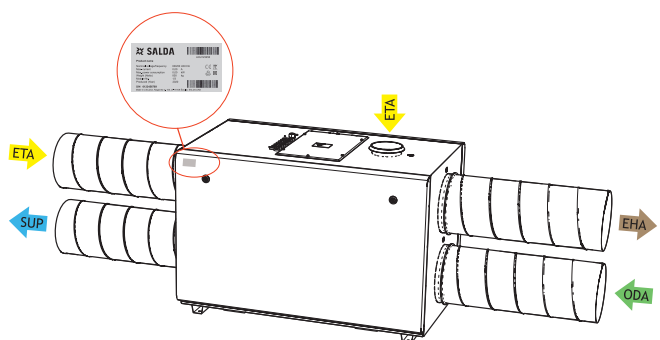

Figure 2.3 Technical label place and air duct indication (left version)

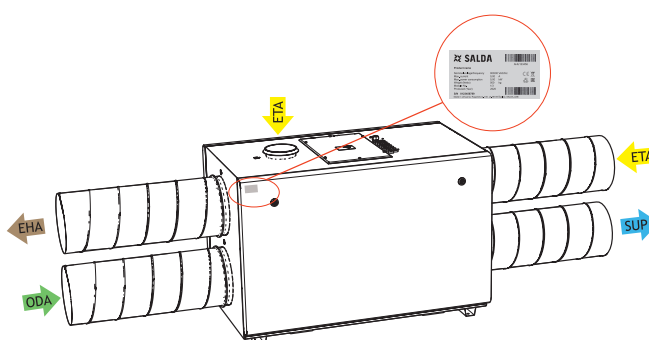

Figure 2.4 Technical label place and air duct indication (right version)



NOTE. Ducts are not parts of the unit.

3. SAFETY INSTRUCTIONS AND PRECAUTIONS

Read these instructions very carefully before installing and using this equipment. Installation, connection and maintenance should be carried out by a qualified technician and in accordance with local regulations and legislation.

The company shall take no responsibility for the injuries or damaged property if the safety requirements are not followed or the device is modified without the permission of the manufacturer.

Main safety rules

Danger



- Before carrying out any electrical or maintenance works, make sure that the device is disconnected from the mains and that all moving parts of the device have stopped.
 - Make sure that the fans are not accessible through air ducts or branch openings.
 - If any liquids on electric parts or connections that bear voltage are noticed, stop the operation of the device.
 - Do not plug the device into the mains that differ from the one indicated on the label or on the housing.
 - Voltage of the mains should comply with the electrotechnical parameters indicated on the label.
 - The device should be earthed in accordance with the regulations on the installation of electric devices. Turning on and using an un-earthed device is not allowed. Follow the requirements specified on the device's labels that indicate danger.
-

Warnings



- Connection of electricity and maintenance of the device should be performed by qualified personnel only and in accordance with the manufacturer's instructions and safety requirements.
 - In order to reduce the risk during installation and maintenance, suitable protective clothing must be worn.
 - Beware of sharp angles while carrying out installation and maintenance works.
 - Do not touch heating elements until they haven't cooled down.
 - Some devices are heavy, you should be very careful while transporting and installing them. Use suitable lifting equipment.
 - When connecting electricity to the mains, a circuit breaker of suitable size must be used.
-

Warning!



- If the device is installed in a cold environment, make sure that all connections and tubes are properly isolated. Intake and discharge air ducts should be isolated in all cases.
 - Openings of the ducts should be covered during transportation and installation.
 - Make sure not to damage the heater when connecting the piping of the water heater. For tightening up, use a wrench/spanner.
-

Before starting up the device



- Make sure, that there are no strange objects inside the device;
 - Manually check fans to make sure they are not stuck or blocked;
 - If rotary heat exchanger is installed in the device, make sure that it is not stuck or blocked;
 - Check the earthing;
 - Make sure that all components and accessories are connected in accordance with the wiring diagram or provided instructions.
-

4. INFORMATION ABOUT THE PRODUCT

4.1. DESCRIPTION

RIRS H EKO 3.0 is a residential air handling unit with a high efficiency (up to 73 %) rotor heat exchanger. The unit supplies ventilation in home and takes the heat from exhaust air. AHU complies with ErP 2018 requirements. The unit is operated by a separate remote control panel or through separate MB-Gateway by PC. Remote control panel and MB-Gateway are optional and not included in standard package.

⚠ Not suitable for operation in pools, saunas and other similar premises.

4.2. DIMENSIONS AND WEIGHT

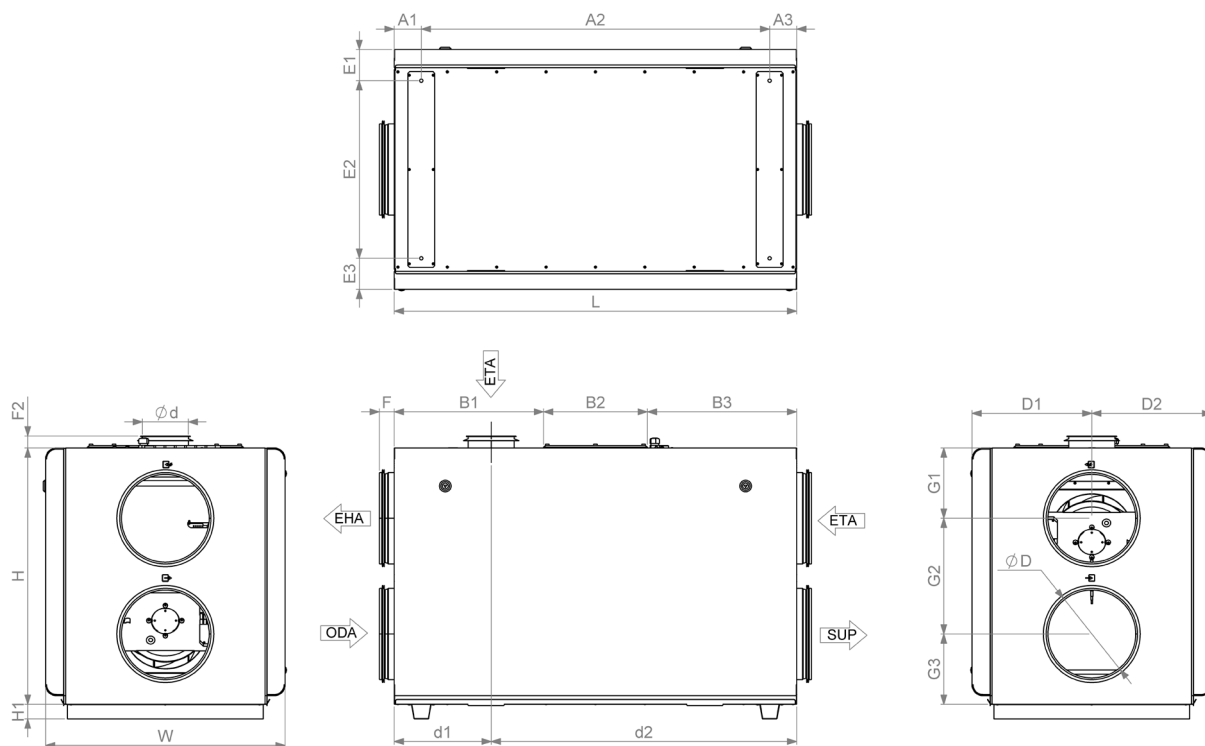

Figure 4.2.1 RIRS 400-700 H R dimensions

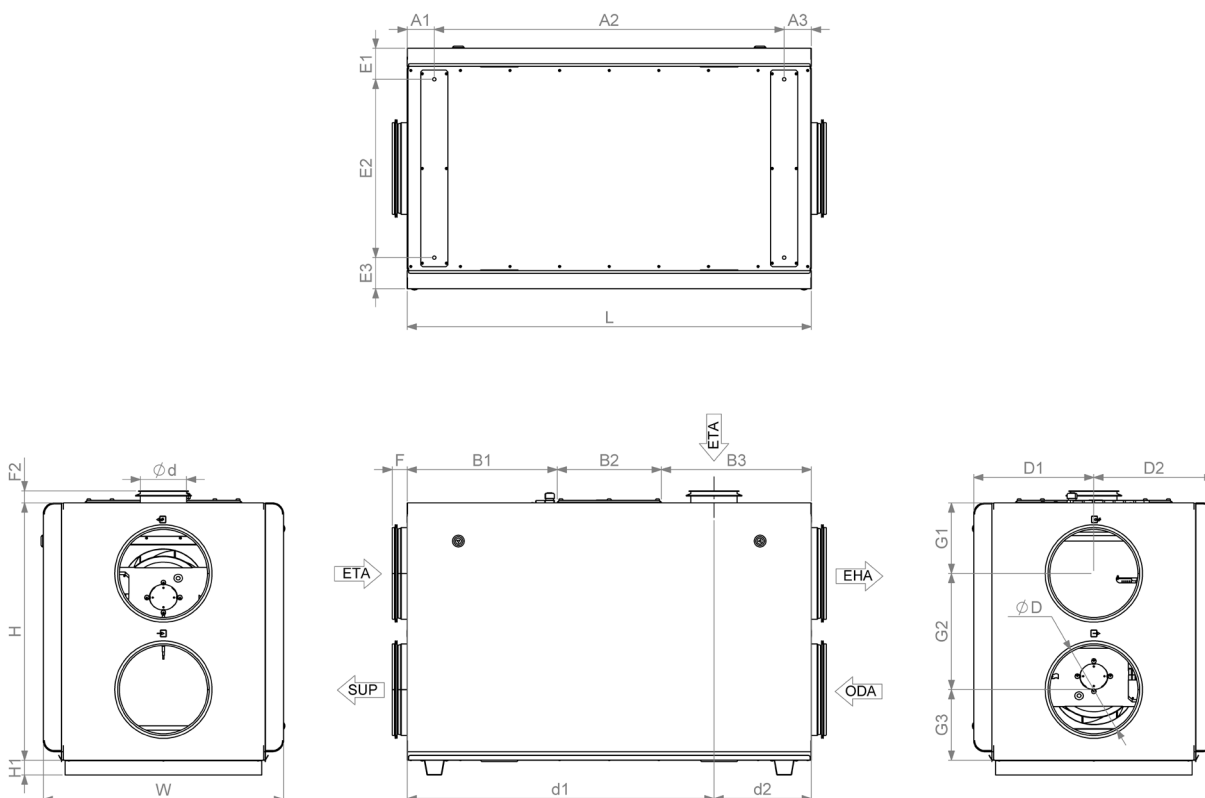

Figure 4.2.2 RIRS 400-700 H L dimensions

RIRS EKO 3.0		400 HEL	400 HER	400 HWL	400 HWR	500 HEL	500 HER	500 HWL	500 HWR	700 HEL	700 HER	700 HWL	700 HWR
L	[mm]	1 000								1 100			
W	[mm]	560								655			
H	[mm]	610								700			
ØD	[mm]	200								250			
Ød	[mm]	125											
F	[mm]	31								41			
F2	[mm]	32											
H1	[mm]	40											
A1	[mm]	72								74			
A2	[mm]	856								952			
A3	[mm]	72								74			
B1	[mm]	385	330	385	330	385	330	385	330	408			
B2	[mm]	285								284			
B3	[mm]	330	385	330	385	330	385	330	385	408			
D1	[mm]	280								327			
D2	[mm]	280								327			
E1	[mm]	85											
E2	[mm]	390								485			
E3	[mm]	85											
G1	[mm]	175								192			
G2	[mm]	267								316			
G3	[mm]	168								192			
d1	[mm]	753	247	753	247	753	247	753	247	835	265	835	265
d2	[mm]	247	753	247	753	247	753	247	753	265	835	265	835
WEIGHT	[kg]	78		78	74	73		81		100	96	96	95

4.3. TECHNICAL DATA

RIRS EKO 3.0		400 HE	400 HW	500 HE	500 HW	700 HE	700 HW
EXHAUST AIR FAN							
phase/voltage	[50 Hz/VAC]	1/230		1/230		1/230	
power/current	[kW/A]	0,09 / 0,74		0,15 / 1,18		0,17 / 1,75	
speed	[min ⁻¹]	3560		2860		2860	
control input	[VDC]	0-10		0-10		0-10	
protection class		IP54		IP44		IP54	
SUPPLY AIR FAN							
phase/voltage	[50 Hz/VAC]	1/230		1/230		1/230	
power/current	[kW/A]	0,09 / 0,74		0,15 / 1,2		0,17 / 1,75	
speed	[min ⁻¹]	3560		2860		2860	
control input	[VDC]	0-10		0-10		0-10	
protection class		IP54		IP44		IP54	
Integrated electrical heater	[kW]	1,2	-	1,2	-	2,0	-
Total power/current consumption	[kW/A]	1,38 / 6,78	0,2 / 1,58	1,6 / 8,06	0,31 / 2,46	2,34 / 12,2	0,34 / 3,6
Automatic control integrated		PRV	PRV	MCB / PRV	PRV	PRV	PRV
Insulation of walls	[mm]	50		50		50	
Exhaust air filter (class, dimensions LxWxH)	[mm]	MPL 450x170x46 ePM10-55		MPL 450x170x46 ePM10-55		MPL 545x260x46 ePM10-55	
Supply air filter (class, dimensions LxWxH)	[mm]	MPL 450x170x46 ePM1-70		MPL 450x170x46 ePM1-65		MPL 545x260x46 ePM1-70	
Device protection class		IP 34		IP 34		IP 34	

Acoustic data: check the product page on www.salda.it



Not suitable for installation in living rooms: additional noise insulation required.

4.4. OPERATING CONDITIONS

RIRS EKO 3.0	400 HE	400 HW	500 HE	500 HW	700 HE	700 HW
Outdoor air temp. without frost protection	-23 .. 40 °C	-23 .. 40 °C	-23 .. 40 °C	-23 .. 40 °C	-23 .. 40 °C	-23 .. 40 °C
Ambient air temp.	5 .. 40 °C	5 .. 40 °C	5 .. 40 °C	5 .. 40 °C	5 .. 40 °C	5 .. 40 °C
Min. extracted air temp	15 °C	15 °C	15 °C	15 °C	15 °C	15 °C
Max. extracted air humidity	60 %	60 %	60 %	60 %	60 %	60 %
Max. ambient air humidity	70 %	70 %	70 %	70 %	70 %	70 %
Operation environment	indoor	indoor	indoor	indoor	indoor	indoor

4.5. STANDARD PACKAGE OF COMPONENTS

RIRS EKO 3.0	400 HE	400 HW	500 HE	500 HW	700 HE	700 HW
Key 291103	1	1	1	1	1	1

4.6. DESCRIPTION OF COMPONENTS

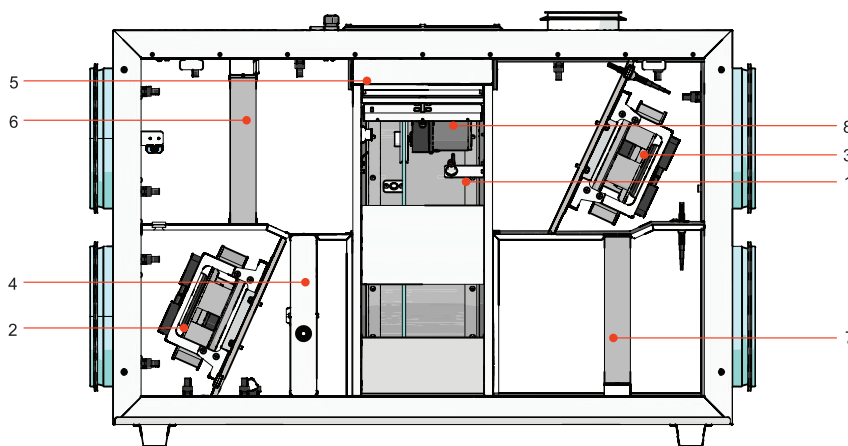

Figure 4.6.1 RIRS HE EKO 3.0 construction (left side)

- 1 - Rotor heat exchanger; 2 - Supply fan; 3 - Exhaust fan; 4 - Electrical heater; 5 - Control board; 6 - Extract air filters (panel); 7 - Supply air filter (panel); 8 - Rotor motor.

5. INSTALLATION

5.1. RECEPTION OF GOODS

Each device is carefully checked before transportation. When receiving the goods, checking the devices for any damage made during transportation is recommended. If any damage to the unit is observed, immediately contact the representatives of a transport company. Please inform the representative of the manufacturer, if any deviation of the device is noticed.

5.2. TRANSPORTATION AND STORAGE

- All units are factory-packaged to withstand normal conditions of transportation.
- When unpacking, check the unit for any damage made during transportation. Installing the damaged units is not allowed!
- The packaging is used for protection purposes only!
- When unloading and storing the units, use suitable lifting equipment to avoid damage and injuries. Do not lift units by holding on power supply cables, connection boxes, air extract or exhaust flanges. Avoid hits and shock overloads. Before installation, the units must be stored in a dry room with relative air humidity not exceeding 70 % (at +20 °C) and with an average ambient temperature ranging between +5 °C and +30 °C. The storage place must be protected against dirt and water.
- The units must be transported to the storage place or installation site using forklifts.
- The recommended storage period should not be longer than one year. In case of storing the units for a period longer than one year, checking if the fan bearings and motor rotate without difficulty (turning the impeller by hand) and if the electric circuit insulation is not damaged or the moisture has not accumulated must be performed before the installation of the unit.

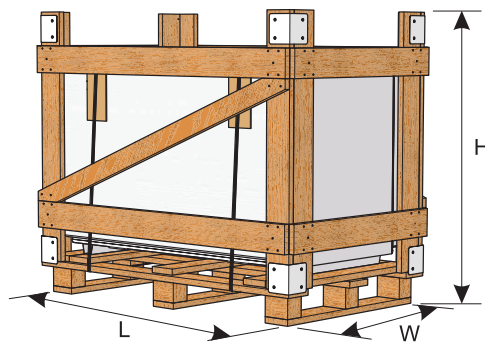

	H	W	L	Max. number of transported packages
	[mm]	[mm]	[mm]	[pcs.]
RIRS EKO 3.0				
400 HE	955	675	1080	1
400 HW	955	675	1080	1
500 HE	955	675	1080	1
500 HW	955	675	1080	1
700 HE	1055	785	1270	1
700 HW	1055	785	1270	1

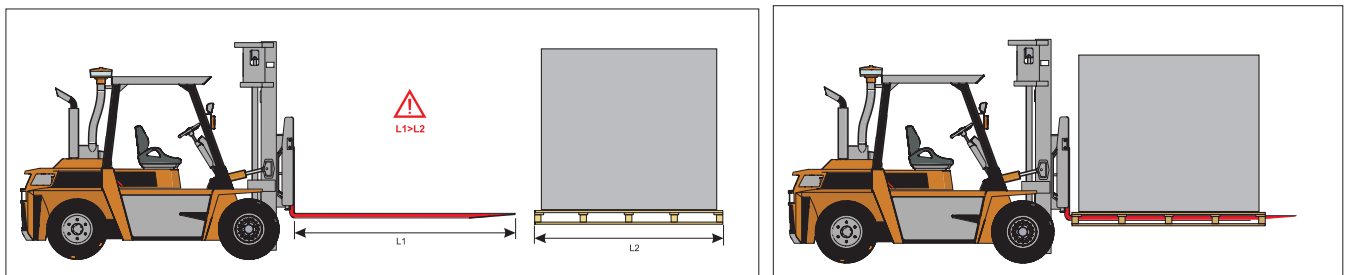

Figure 5.2.1 Lifting by forklift.



To prevent damage to the casing, only a product placed on a pallet should be lifted.

5.3. UNPACKING



Accessories may be packed together with the product. Prior to transporting the unit, the accessories should be unpacked first.

- Remove the film from the unit.
- Remove the bracing packaging tape that keeps the protective profiles in place.
- Remove the protective profiles.

- After unpacking the unit, examine it to make sure that no damage was made during transportation. Installation of damaged units is not allowed!
- Before commencing the installation of the unit, please check if all ordered equipment has been delivered. Any deviation from the ordered equipment list must be reported to the product supplier.

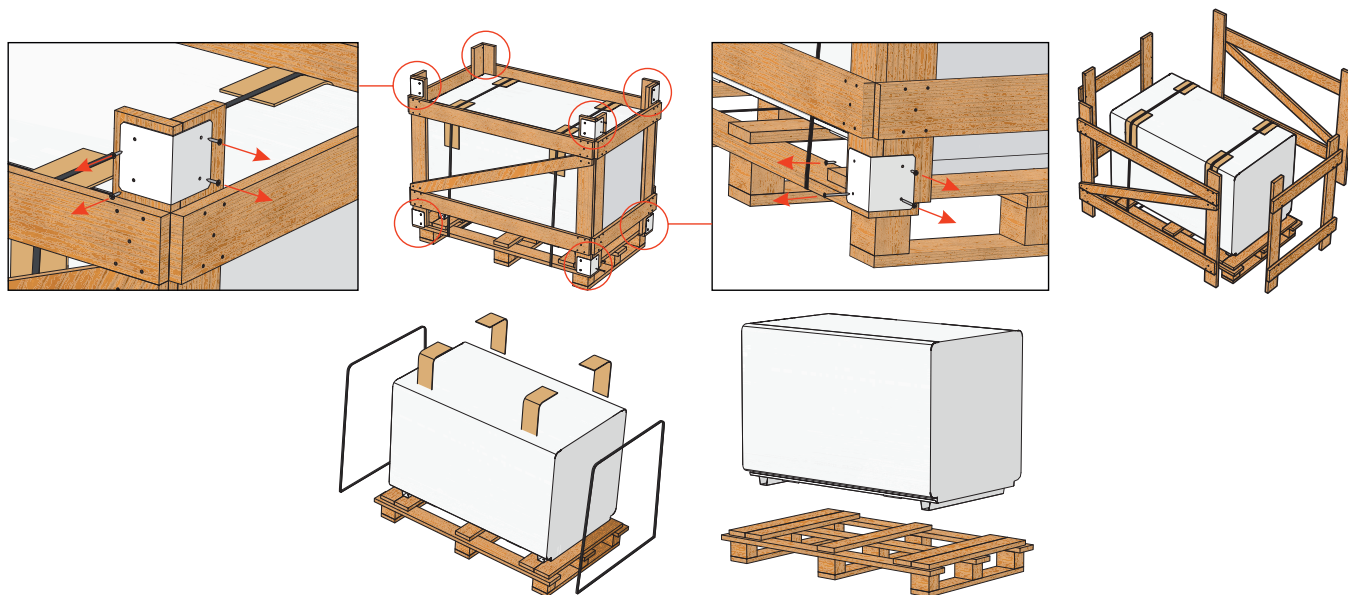

5.4. PIPING AND INSTRUMENTATION DIAGRAM

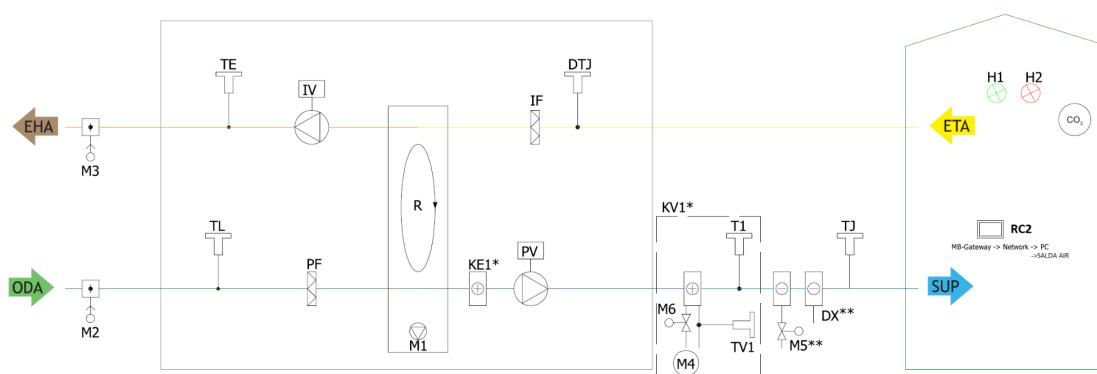

Figure 5.4.1 * KE1 - only in electrical version; * KV1 - used in water version; ** Possible to control (PRV)

THE LIST OF COMPONENTS

PV	Supply air fan	IF	Extract air filter
PF	Supply air filter	IV	Exhaust fan
TE	Exhaust air temperature sensor	TJ	Supply air temperature sensor
DTJ	Extract air temperature and humidity sensor	CO₂	CO ₂ sensor
PC	Computer	KE1	Electric heater*
M2	Outdoor air damper actuator	M3	Exhaust air damper actuator
TL	Outdoor air temperature sensor		Ventilated premises
NET	Network	MB-Gateway	Network module
R	Rotor heat exchanger	DX	DX cooler
KV1	Water heater*	T1	Water heater thermostat*
M4	Water heater circulation pump*	M5	Water cooler valve motor
RC2	Stouch, Flex or ST-SA-Control remote control panel	M6	Water heater valve motor*
TV1	Water heater temperature sensor *	M1	Rotor motor

* Component/possibility to connect it depends on model.

POSSIBLE PCB INPUTS/OUTPUTS

FA	Fire alarm	H1	Working indication output
	Fans speed switch (BOOST)	H2	Alarm indication output
	System mode switch (START/STOP)		

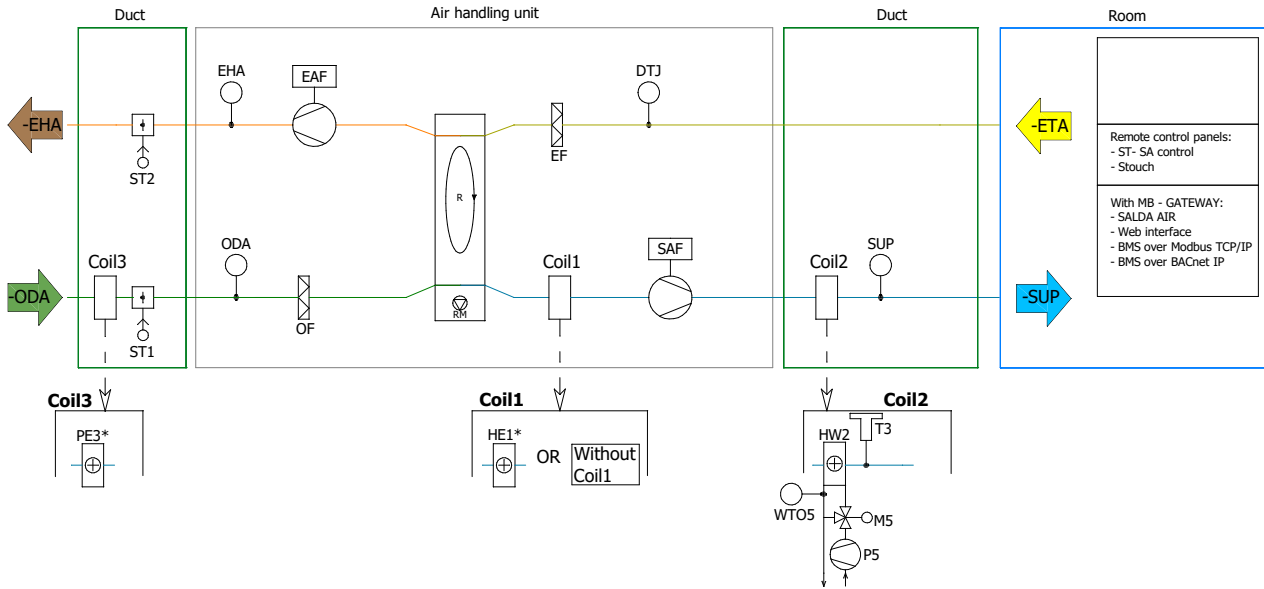

Figure 5.4.2 HE1 - used in electric version; HW2 - used in water version; * Only heater or preheater can be connected at a time (MCB)

List of integrated components		Availability	List of optional accessories		Availability
SAF	Air fan supply	+	HW2	Heater water	One for single Air Handling unit
EAF	Air fan exhaust	+	HE1	Heater electrical	One for single Air Handling unit
OF	Air filter outdoor	+	PE3	Preheater electrical	One for single Air Handling unit
EF	Air filter extract	+	T3	Thermostat HW2 protection	Only with HW2
R	Heat exchanger rotor	+	WT05	Temperature sensor HW2 return water	
RM	Motor heat exchanger	+	P5	Pump HW2 water circulation	
SUP	Air temperature sensor supply	+	M5	Actuator HW2 water valve	
ODA	Air temperature sensor outdoor	+	ST1	Air damper outdoor	+
EHA	Air temperature sensor exhaust	+	ST2	Air damper exhaust	+
DTJ	Air temperature and humidity sensor extract	+		Remote control panel	1
				MB-Gateway interfaces	+

5.5. MOUNTING

- Installation works should be carried out by qualified and trained staff only.
- When connecting air ducts, consider the labels on the casing of the unit.
- Before connecting to the air duct system, the connection openings of the ventilation unit should be closed.
- When connecting the ducts, the air-flow direction indicated on the device housing should be observed.
- Do not connect the bends close to the connection flanges of the unit. The minimum distance of the straight air duct between the unit and the first branch of the air duct in the supply air duct must be 1xD, in air exhaust duct 3xD, where D is the diameter of the air duct.
- It is recommended to use the brackets (accessories). This will reduce the vibration transmitted by the unit to the air duct system and environment.
- Sufficient space must be provided for opening the device door and filter covers.
- If the ventilation unit is a wall-mounted device, it may transmit noise vibrations to the premises. Though the level of noise generated by the fans is admissible, we recommend mounting the unit at a distance of 400 mm from the nearest wall. Where this is not possible, we recommend mounting the unit on the wall of the room where the level of noise is not significant.
- Ducts are connected to the unit in such a way that they could be easily disassembled, and the coil could be removed from the unit when carrying out maintenance, service and/or repair works.



The protective film is used to protect the unit during transportation. It is recommended to remove the film; otherwise, oxidation signs may occur.

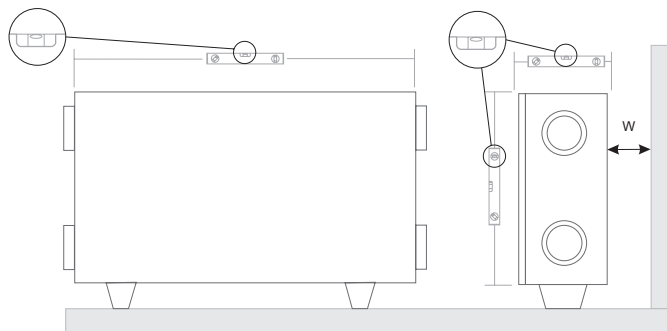

Figure 5.5.1 Horizontal floor-mounting positions on floor (W=400 mm)

5.5.1. UNIT PLACING AND MOUNTING POSITIONING REQUIREMENTS

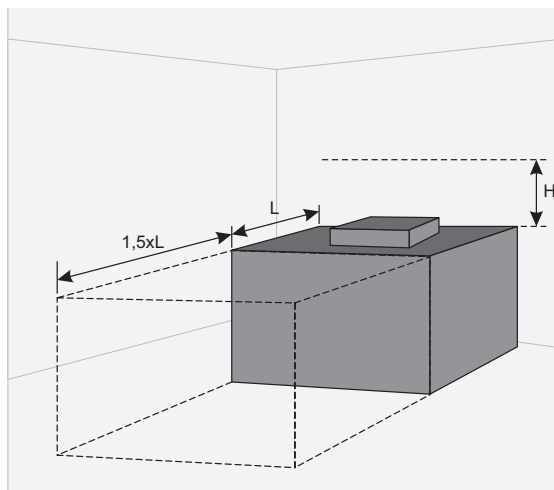

Figure 5.5.1.1 Min. distance to open the door - 1,5xL; Min. distance to open the control box door - H > 400 mm.

5.5.2. FLOOR MOUNTING

- The installation should be performed having positioned the units in the horizontal direction only.
- Install the supporting legs.
- The units are assembled from separate sections.
- They must be adjusted without a gradient.
- Leave space in front (2xL) so that it would be sufficient to open the doors and to remove or install a required component.

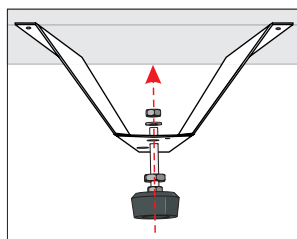

Figure 5.5.2.1 Floor mounting

5.6. CONNECTION OF THE AIR DUCT

- The connected air ducts must not be bent and must be fixed separately.
- Make sure that the fans may not be accessed through air duct heads. Otherwise, a protective grid should be installed. You may choose the grid from the range of products provided on our website <https://select.salda.it>.
- Do not reduce the diameter of the piping near the air inlet or exhaust ducts. If you want to reduce the airflow speed in the system, also to reduce pressure and noise level, you can increase the diameter.
- In order to reduce the level of noise in the air supply system, install silencers (see the chapter on air supply system installation).
- In order to reduce air loss in the system, the air ducts and profile components should be of class C or higher. The catalogue of the above-mentioned items can be found on our website <https://select.salda.it>.
- External air and exhaust system piping should be isolated in order to prevent heat loss and condensation.
- We recommend to maintain a distance of up to 8 meters between air intake and air exhaust ducts. The air intake point should be installed away from potential air pollution sources.

- When installing air ducts next to the ventilation equipment, brackets must be used. They suppress vibration and assure secure installation of the various system parts. The necessary brackets can be found in our catalogue or on our website <https://select.salda.it>.
- Air ducts are often mistakenly connected in an inappropriate location. The ventilation units bear the labels indicating the correct air duct connection layout. Before starting up the system, carefully check if all related works have been performed properly.



For flange diameters see chapter **“DIMENSIONS AND WEIGHT”**.

5.7. CONNECTION OF THE UNIT TO THE ELECTRIC NETWORK

- Supply voltage to the unit must be connected by a qualified specialist following the manufacturer's instructions and applicable safety guidelines.
- The unit's power network voltage must correspond to the electro-technical specifications of the unit indicated in the technical decal.
- The unit's voltage, power and other technical specifications are provided in the unit's technical decal (on the unit casing). The unit must be connected to the voltage plug socket of the grounded power network in accordance with the applicable requirements.
- The unit must be earthed according to electrical equipment installation regulations.
- Using extension wires (cables) and power network plug socket distribution devices is not allowed.
- Prior to carrying out any ventilation unit installation and connection works (before the unit is commissioned), the unit must be disconnected from the power network.
- After installation of the ventilation unit, the power network plug socket must be accessible at any time. If the unit is equipped with circuit breaker, disconnection from the power network is performed through the two-pole or four-pole circuit breaker (by disconnecting phase poles and neutral).
- Before it is connected to the power network, the unit must be carefully checked for any damage (operation, control, and measurement nodes) made during transportation.
- The power cable can be replaced only by a qualified technician, after the evaluation of the rated power and current.



The manufacturer does not assume any liability for personal injuries and property damage due to non-conformance with the provided instructions.

5.8. START-UP RECOMMENDATIONS

5.8.1. SYSTEM PROTECTION

The control board of the unit is equipped with the following integrated devices for the protection against short circuit:

RIRS EKO 3.0	400 HE	400 HW	500 HE	500 HW	700 HE	700 HW
F1	10 A	5 A	10 A	5 A	15 A	10 A
F2	6,3 A	1 A	6,3 A	1 A	10 A	1 A
RIRS EKO 3.0 MCB						
F1	10 A					

It is recommended to use the unit with an external electrical protection device.

RIRS EKO 3.0	400 HE	400 HW	500 HE	500 HW	700 HE	700 HW
Mains Fuse	10 A	6 A	10 A	6 A	16 A	6A



To ensure safe maintenance of the unit, it is necessary to turn off the main switch and/or external protection device.

5.8.2. PRE START-UP RECOMMENDATIONS OF THE UNIT (IN THE PRESENCE OF THE END-USER)

Prior to start-up, the system must be carefully cleaned. Check for the following:

- Operation systems and unit elements as well as automation and automation devices were not damaged during installation,
- All electrical devices are connected to power supply and fit for service,
- All necessary automation elements are installed and connected to power supply and terminal blocks,
- Cable connection to terminal blocks comply with the existing wiring diagrams,
- All electrical equipment protection components are properly connected (if they are additionally used),
- Cables and wires correspond to all applicable safety and functional requirements, diameters, etc.,
- Earthing and protection systems are properly installed,
- Condition of all seals and sealing surfaces is proper.

6. MAINTENANCE

6.1. SAFETY INSTRUCTION



Unplug the unit from the mains before opening the door (disconnect the power plug from the outlet or in case a two-pole automatic circuit breaker is installed, disconnect it as well. Make sure that it cannot be turned on by the third parties) and wait until the fans completely stop (for about 2 min.).

6.2. GENERAL RECOMMENDATIONS FOR VENTILATION SYSTEM MAINTENANCE

In order to ensure the proper functioning of the system, maintenance requirements and its periods should be observed. Otherwise, the warranty shall be void. Some recommendations are provided in the table below, but they are just advisory, as the need for system maintenance depends on the location of the unit installation, the pollution of the atmosphere, population, working hours, etc.

COMPONENT	DURING START-UP	AT LEAST EVERY 6 MONTHS
Filters	Check the cleanliness of the filters	Replace filters every 3 to 4 months or according to the control device indications. Check cleanliness. Clean, if necessary. Make sure that the impellers are not unbalanced.
Fans	Check the connections and the direction of rotation	Make sure that the impellers do not cause noise when rotated by hand. Make sure that the fastening screws are not loose and free of mechanical damage. Check electrical connections and make sure that these are secured properly and are free of signs of corrosion.
Rotor heat exchanger	Check the cleanliness of the heat exchanger	Check cleanliness and clean, if necessary. Check the tension of a belt.
Control panel	Check the connections	Check the connections.
Electric heater	Check the connections	Clean off dust, and check the electrical components and connections of the heater.
Pressure sensor	Check electrical connections	Check the operation.
Temperature sensor	Check electrical connections	Check the operation.
Air supply and extract system	Check the connections	Clean.
Air duct system	Check the tightness	Clean.
Dampers, diffusers, grid	Check the tightness of connections	Clean.
Switching unit (contactor)		Every 3 to 4 months, visually assess the functioning of the switching unit (contactor), i.e. make sure that its casing has no signs of melting or is not thermally damaged and does not produce any unusual sounds. All the contactors in the product or in its accessories must be checked.

6.3. COVER OPENING



Before opening the covers, first, unplug the unit from the mains, then wait for 2 minutes (until the fans completely stop).

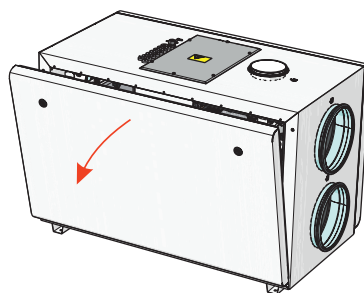

6.4. FILTERS MAINTENANCE

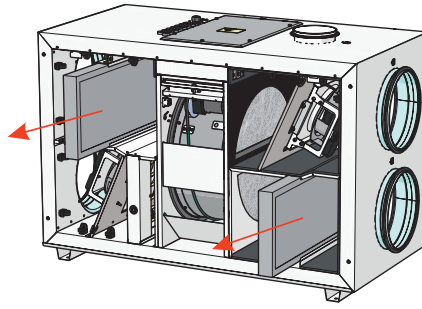

In order to remove the filters, open the door of the unit and take off the filters.

Dirt increases air resistance in the filter, therefore, a lower amount of air is supplied into the premises. Arrows on the filters must comply with the airflow direction.



**After changing the filters, please reload the filter timer. The instruction on reloading is provided in the control panel operation manual or on our website www.salda.it
Operation of the unit without filters is not allowed.**



Change the filters every 3-4 months or according to the notification on the control device.

6.5. ROTOR MAINTENANCE

- Maintenance of rotor heat exchanger must be performed on annual basis, once per year.
- Ensure the gaps of heat exchanger are clean, the brushes are not worn, the belt drive is not worn, and the clamping nodes of the rotor heat exchanger are tight.
- Rotor heat exchanger can be easily removed from the unit. Disconnect the power cord of the motor of heat exchanger, release and raise the clamp of the rotor heat exchanger section, and then remove the heat exchanger.
- Heat exchanger must be cleaned using the solution of warm water and non-corrosive toward aluminium alkaline agent or an air stream. Applying direct stream of liquid is not recommended, because this can cause damage to the device.
- While cleaning, make sure that no moisture and liquid will enter into the motor of the heat exchanger.
- Having reinstalled the heat exchanger, fasten its section with the clamp. Connect the heat exchanger motor.

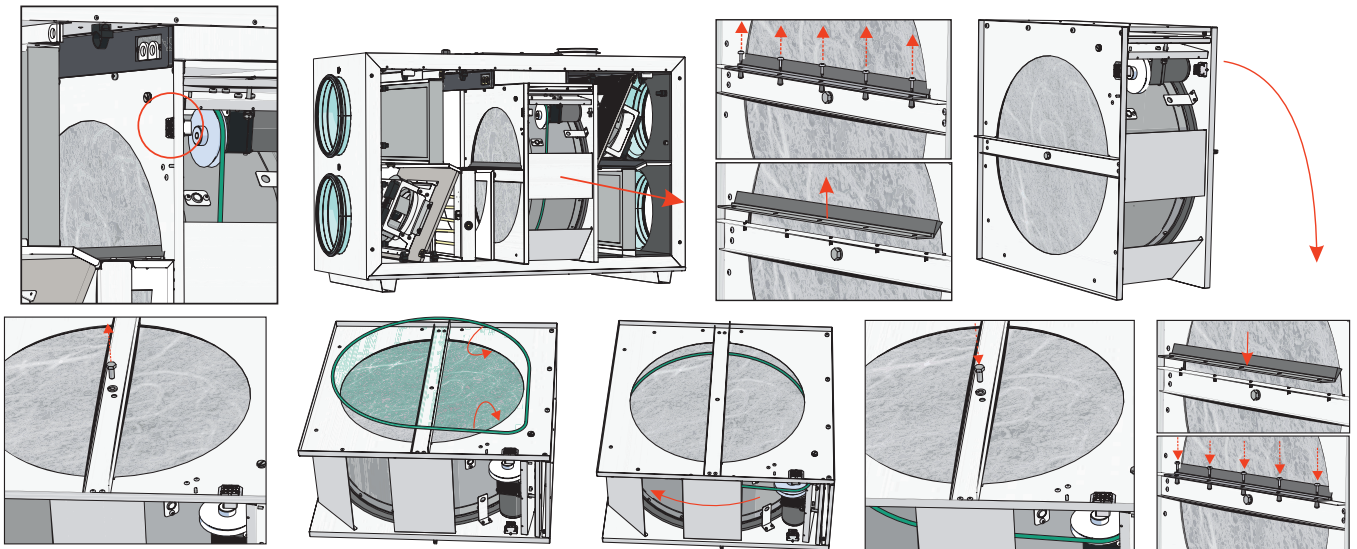

CAUTION: the heat exchanger cannot be used when the filters are removed!

6.6. FANS MAINTENANCE

- Fan maintenance should be performed by experienced and trained staff only.
- The fan should be inspected and cleaned at least once per year.
- Prior to commencing any maintenance or repair works, make sure the unit is disconnected from the power source.
- Proceed to maintenance and repair after any fan rotation is stopped.
- Observe staff safety regulations during the maintenance and repair works.
- The fans features a heavy-duty ball bearing design. The motor is completely sealed and free of maintenance.
- Detach the fan from the unit.
- The impeller should be particularly checked for built-up material or debris that may cause an imbalance. An excessive imbalance may lead to accelerated wear on the motor bearings and cause vibration.
- Clean the impeller and inside the housing with a mild detergent and a damp soft cloth.

- Do not use high-pressure cleaners, abrasive materials and sharp tools or caustic solvents that may scratch or damage the housing and impeller.
- Do not plunge the motor in any fluid while cleaning the impeller. Make sure the impeller's balance weights are in place.
- Make sure the impeller is free of any obstacles.
- Install the fan back into the unit. Connect fan power and control signals.
- In case the fan does not automatically start up or stop after maintenance, contact the manufacturer. The malfunction of the fan can be identified by the pressure in the system (when pressure switches are connected). In case of any fault in the fan motor, a notice will appear on the control panel.

⚠ Prior to commencing any maintenance or repair works, make sure the unit is disconnected from the power source.

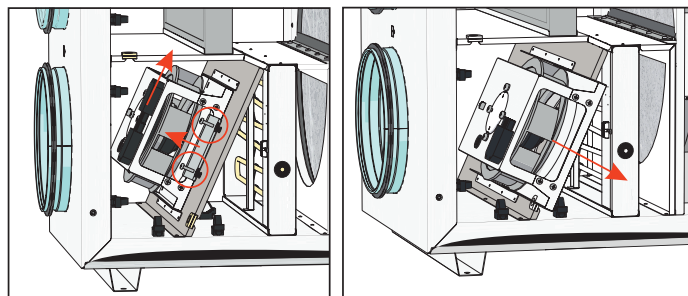

6.7. HEATER MAINTENANCE

- In case manual protection is activated, check for a fault before pressing the RESET button. If the fault is identified after it has been rectified, press the RESET button using a screwdriver or a similar object.
- Electrical heater does not require additional servicing. The filters must be replaced as described above.
- Heaters are equipped with 2 thermal protection devices: an automatic self-resetting protection device that is activated at +50 °C, and a manually restored protection device that is activated at +100 °C.
- After activation of the manually restored protection device, make sure that the unit is disconnected from the power supply. Wait until all heating elements cool down and the fans stop completely. After the failure is detected and rectified, press the RESET button before starting the unit. The failure can be identified by a qualified technician only.
- If necessary, the electric heater can be removed. Disconnect the electrical connector from the heater and remove the heater.

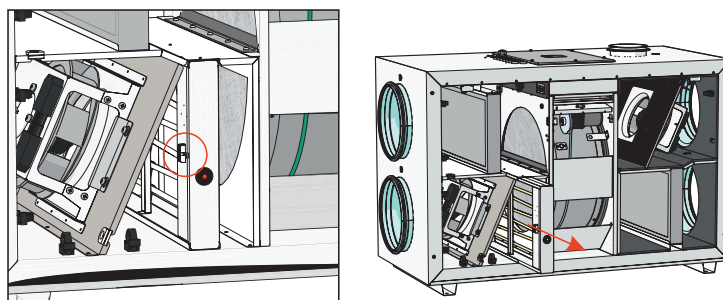

6.8. CONTROL BOARD MAINTENANCE

- Disconnect product unit from electric power source.
- Unscrew the bolts on the control box.
- Remove the control box cover.
- Disconnect all necessary cables, wires, hoses and connectors in order to remove the control board and unscrew the control board mounting bolts.
- Remove the control board.
- To reassemble, follow all maintenance steps in reverse order. When re-connecting cables, wires, hoses and connectors, make sure to match each wire, hose and connector to the corresponding connection terminal and connector.

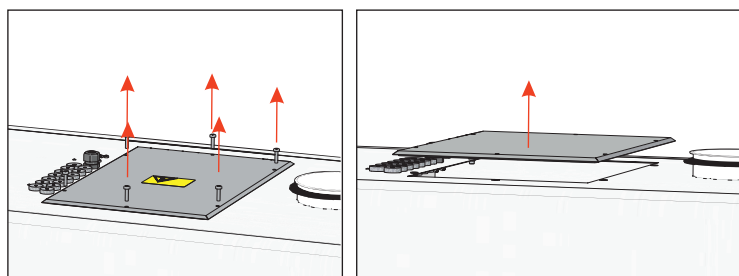

7. CONTROL

7.1. DEVICE CONTROL

Ventilation unit equipped with PRV control board can be controlled with remote controller, WEB interface or mobile app via MB-GATEWAY and BMS (building management system). More information provided in the table below.

With MB-GATEWAY	Remote control panels	BMS direct connection	Wireless communication
Web interface SALDA AIR mobile application BMS over Modbus TCP/IP BMS over BACnet TCP/IP	Stouch ST-SA-Control FLEX	Modbus RTU (RS485)	MB-GATEWAY + WIFI router

Ventilation unit equipped with MCB control board can be controlled with remote controller, WEB interface or mobile app via MB-GATEWAY and BMS (Building Management System). More information provided in the table below.

With MB-GATEWAY	Remote control panels	BMS direct connection	Wireless communication
Web interface SALDA AIR mobile application BMS over Modbus TCP/IP BMS over BACnet TCP/IP	Stouch ST-SA-Control	Modbus RTU (RS485)	MB-GATEWAY + WIFI router

7.2. DEVICE FUNCTIONS

PRV control board operation functions and control of the device depends on the following:

1. Selected control interface (remote control panel, MB-GATEWAY, etc.). The selected interface affects access to the information and settings, however, it does not affect the logic of control. Full access to the information and settings is available on FLEX, ST-SA-Control, MB-GATEWAY WEB application and SALDA AIR mobile application.
2. Unit configuration (internal/external components, sensors and control board settings).

All MCB control boards has the same software with all functions included. Full function list and description you can find on the MCB control board manual. However, operation and control of the device depends on the following factors:

1. Selected control interface (remote control panel, MB-GATEWAY, etc.). The selected interface affects access to the information and settings, however, it does not affect the logic of control. Full access to the information and settings is available on ST-SA-Control, MB-GATEWAY WEB application and SALDA AIR mobile application.
2. Unit configuration (internal/external components, sensors and control board settings).



Refer to the instruction manual of the existing control device for unit control instructions.

8. CONNECTION OF ACCESSORIES

8.1. FIRE PROTECTION SIGNAL INPUT (FIRE PROTECTION INPUT (NC))

8.1.1. PRV CONTROL BOARD

Fire protection signal input must be normally closed, until the fire protection system is not connected a jumper is installed in the factory.

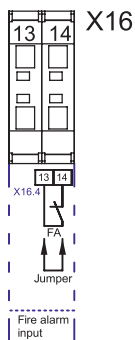

8.1.2. MCB CONTROL BOARD

Fire protection signal input must be normally closed, until the fire protection system is not connected a jumper is installed in the factory.

MCB:

X4: 1, 2

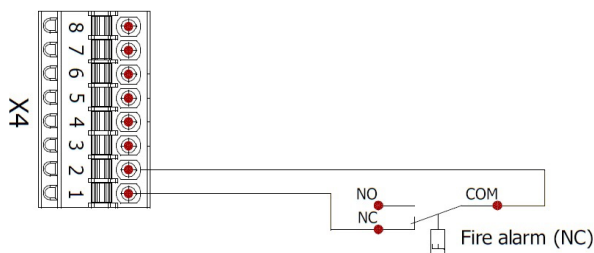

8.2. EXTERNAL CO₂ /PRESSURE SENSORS

8.2.1. PRV CONTROL BOARD

RIRS H EKO 3.0 units have two connections for external CO₂/PRESSURE (input 0-10 VDC) sensors

Sensors connection:

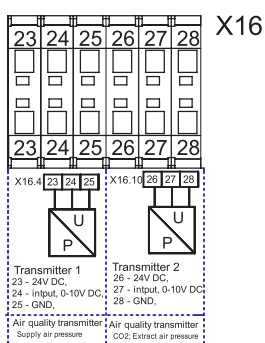

These sensors are intended for the following 3 functions: supply air pressure, extract air pressure and extract CO₂ detection. Supply air pressure is measured inside the supply air duct referenced to the unit's surrounding area. Extract air pressure is measured inside the extract air duct referenced to the unit's surrounding area. The CO₂ transmitter is installed in the extract air duct or room.

8.2.2. MCB CONTROL BOARD

RIRS H EKO 3.0 MCB units come with the integrated RH sensor connected. These units do not have option for external CO₂/PRESSURE/RH (input 0-10 VDC) sensors.

8.3. ROOM CO₂ TRANSMITTER INSTALLATION RECOMMENDATION

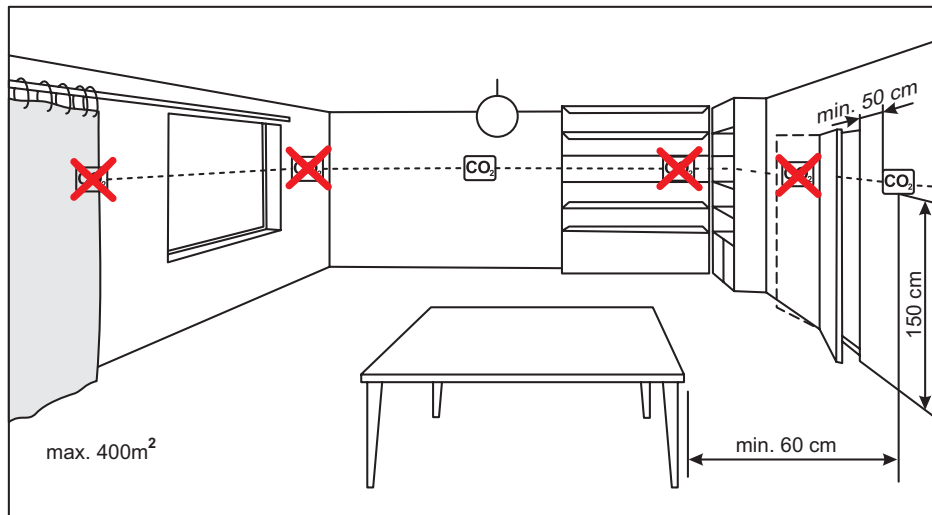

If the duct CO₂ transmitter is used, it must be installed in the extract air duct. To install duct transmitters, hole drilling tools are required.

8.4. CO₂ CONCENTRATION ACCORDING TO PETTENKOFER LIMIT

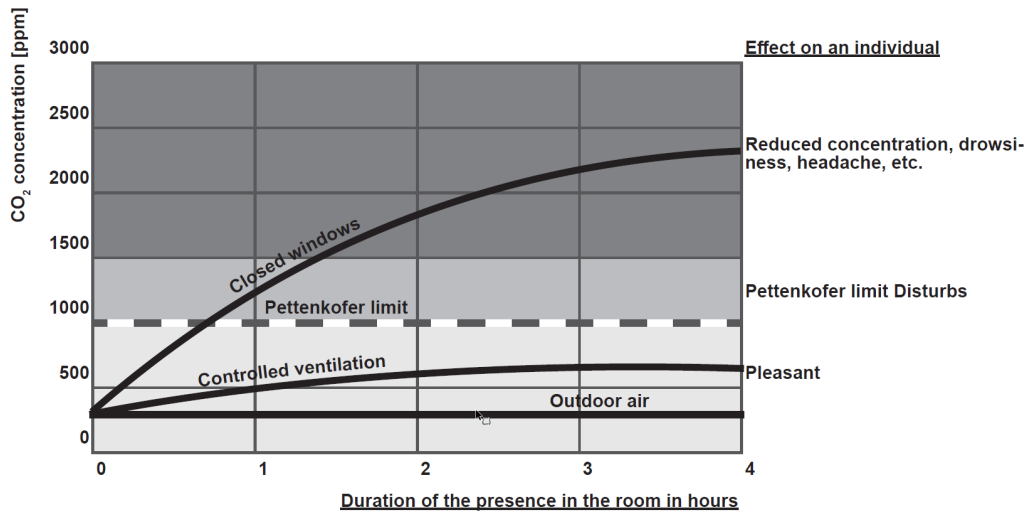

8.5. CONNECTION OF SUPPLY AND EXTRACT AIR DAMPERS

8.5.1. PRV CONTROL BOARD

Product RIRS H EKO 3.0 can be equipped with supply air and extract air dampers. Dampers are controlled by Open/Close or Spring-return actuators.

Wiring diagram for RIRS 400-700 HE EKO 3.0

M2, M3 – Open/Close damper actuators. Upon activation of outputs X16:17, X16:20 the dampers shall open, Upon activation of outputs X16:16, X16:19 the dampers shall close.

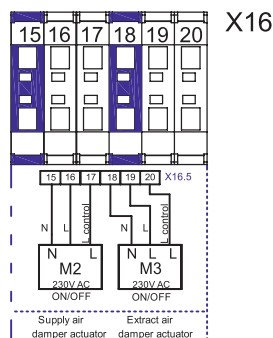

Wiring diagram for RIRS 400-700 HW EKO 3.0

M2 – Spring-return damper actuator. M3 – Open/Close damper actuator. Upon activation of outputs X16:17, X16:20, the dampers open. Upon activation of output X16:19, the extract air damper close. The supply air damper is controlled by spring-return actuator so that when output X16:16 is deactivated, the supply air damper closes.

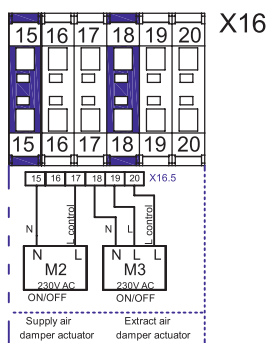

8.5.2. MCB CONTROL BOARD

RIRS H EKO 3.0 MCB can be equipped with outdoor air and extract air dampers. The dampers are controlled by Open/Close actuators.

Wiring diagram RIRS H EKO 3.0 MCB

Upon activation of output X10:3, the dampers open. Upon activation of output X10:4, the dampers close.

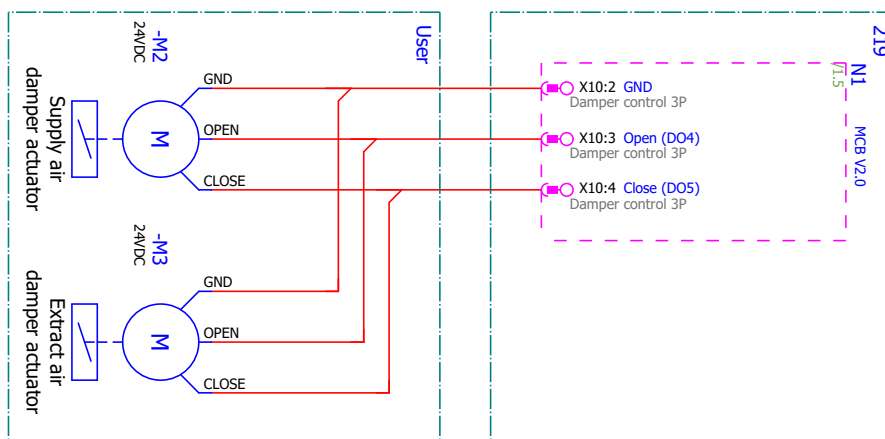

8.6. CONNECTION OF REMOTE CONTROL PANEL OR MODBUS

8.6.1. PRV CONTROL BOARD

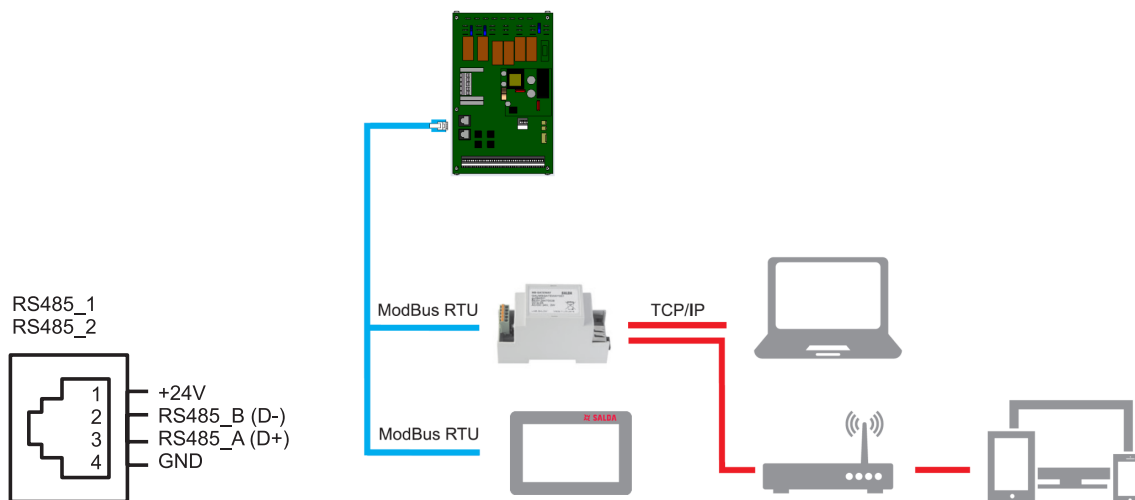

8.6.2. MCB CONTROL BOARD

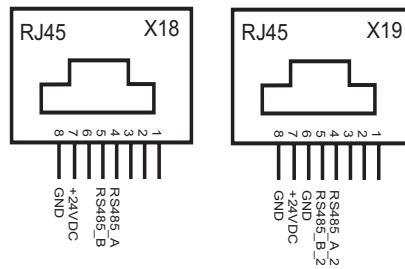

SL1 DIP switch	1	2	3
Purpose (ON position)	120R line termination resistor	1kR connection line pull-up resistor	1kR connection line pull-down resistor

8.6.3. “MCB TOOL” PROGRAM DESCRIPTION

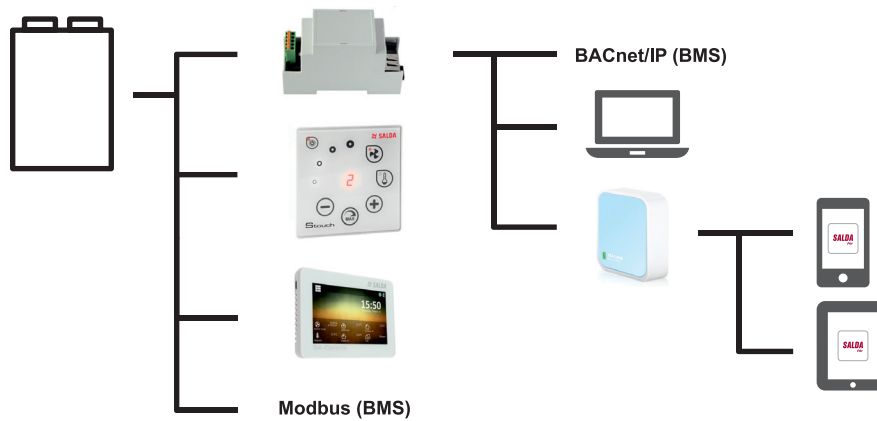

The app 'MCB tool' is intended for importing MCB settings of the control board from MCB to your PC storage media and to export the MCB settings from the PC storage media to MCB. Download the app from http://www.salda.it/en/products/category/download_page/.

1. Choose connection type
 - a. Modbus RTU (connect with RS485 converter)

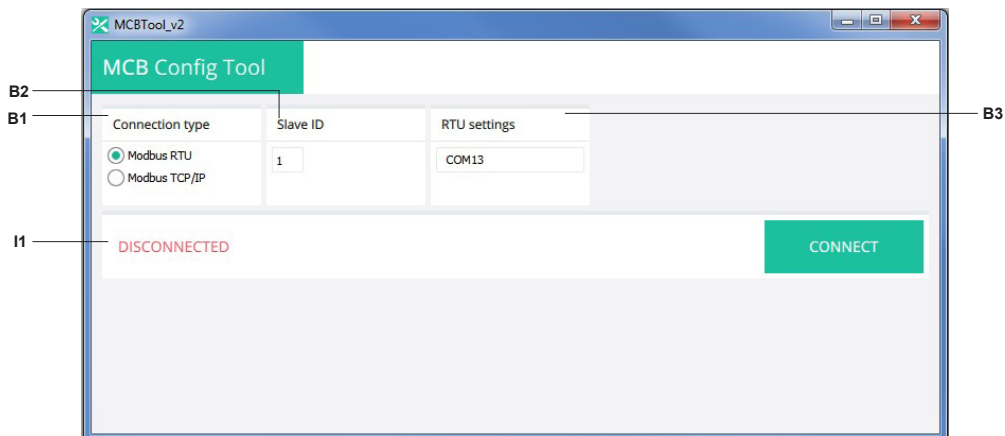

I1	Connection status	B2	Set Modbus slave ID
B1	Select connection type	B3	Select COM port of RS485 converter

b. Modbus TCP/IP (connect with TCP/IP Modbus gateway (MB-GATEWAY))

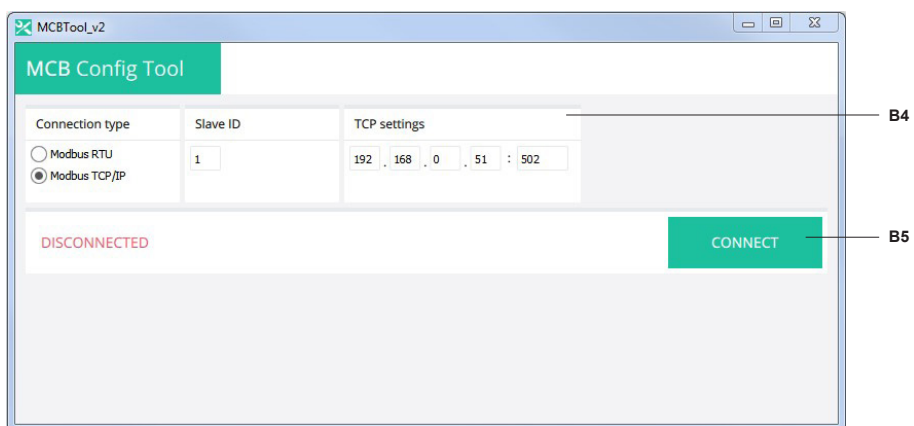

B4	Set IP of TCP/IP Modbus gateway (MB-GATEWAY)	B5	Press to connect
-----------	--	-----------	------------------

2. Connect to device (press **CONNECT** button)

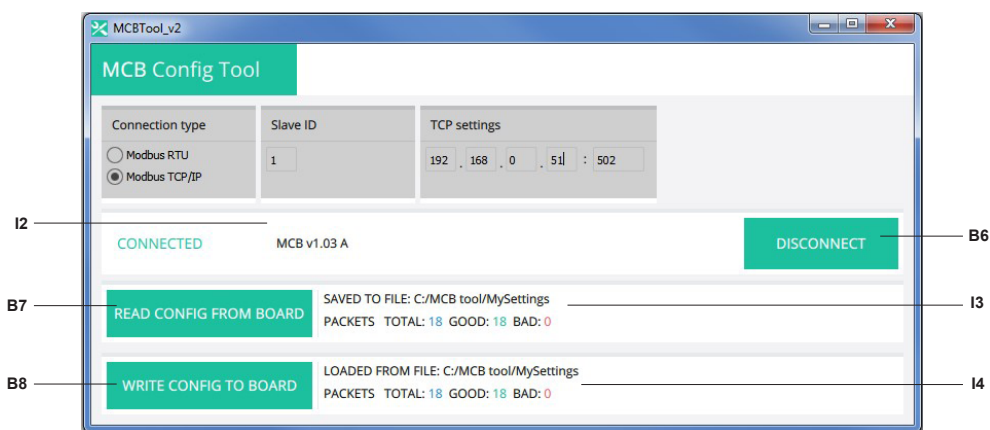

I2	Device software version	B6	Press to disconnect from device
I3	Configuration read status	B7	Press to read configuration from device
I4	Configuration write status	B8	Press to write configuration to device

3. Read the configuration from the device and save to your PC (press **READ CONFIG FROM BOARD** button and enter the configuration file name).

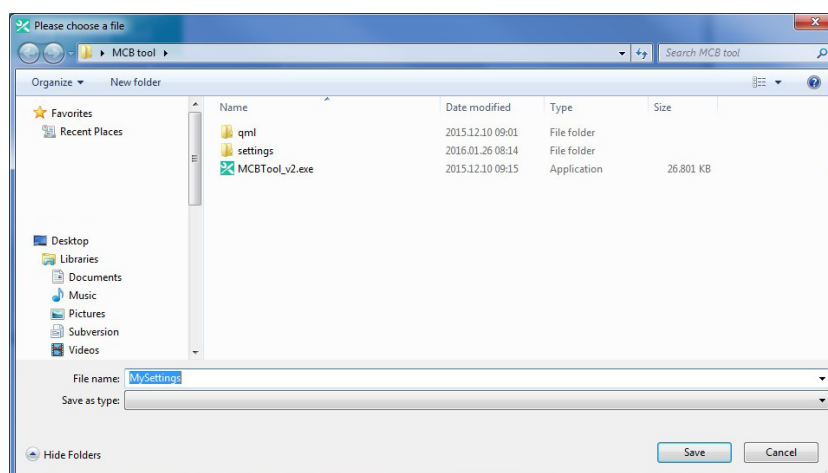

4. Write the configuration to the device from your PC (press **WRITE CONFIG TO BOARD** button and select configuration file).

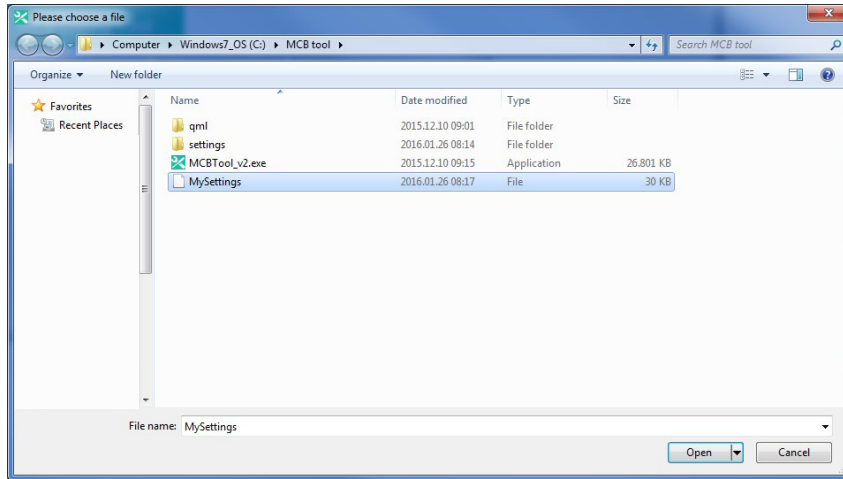

8.7. WATER HEATER CIRCULATION PUMP AND VALVE ACTUATOR

Water heater circulation pump and valve actuator can only be connected to the units that are designed to operate with water heater (RIRS HW EKO 3.0 units).

Wiring diagram

Valve actuator is controlled by 0-10 VDC signal. Circulation pump is controlled by On/Off signal.

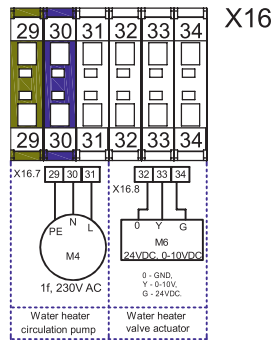

8.8. RECOMMENDED SCHEME FOR CONNECTION OF INTERNAL AND EXTERNAL COMPONENTS

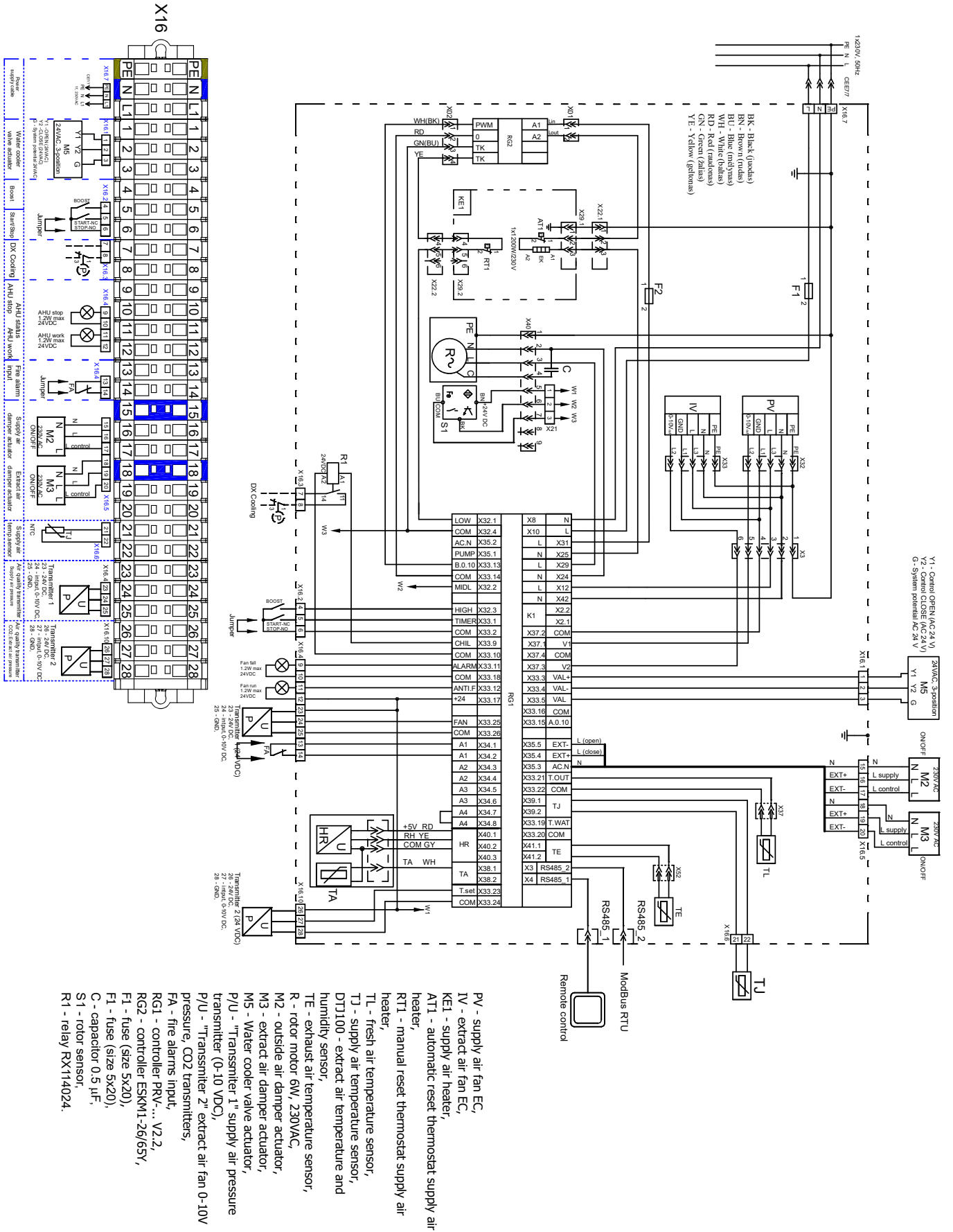
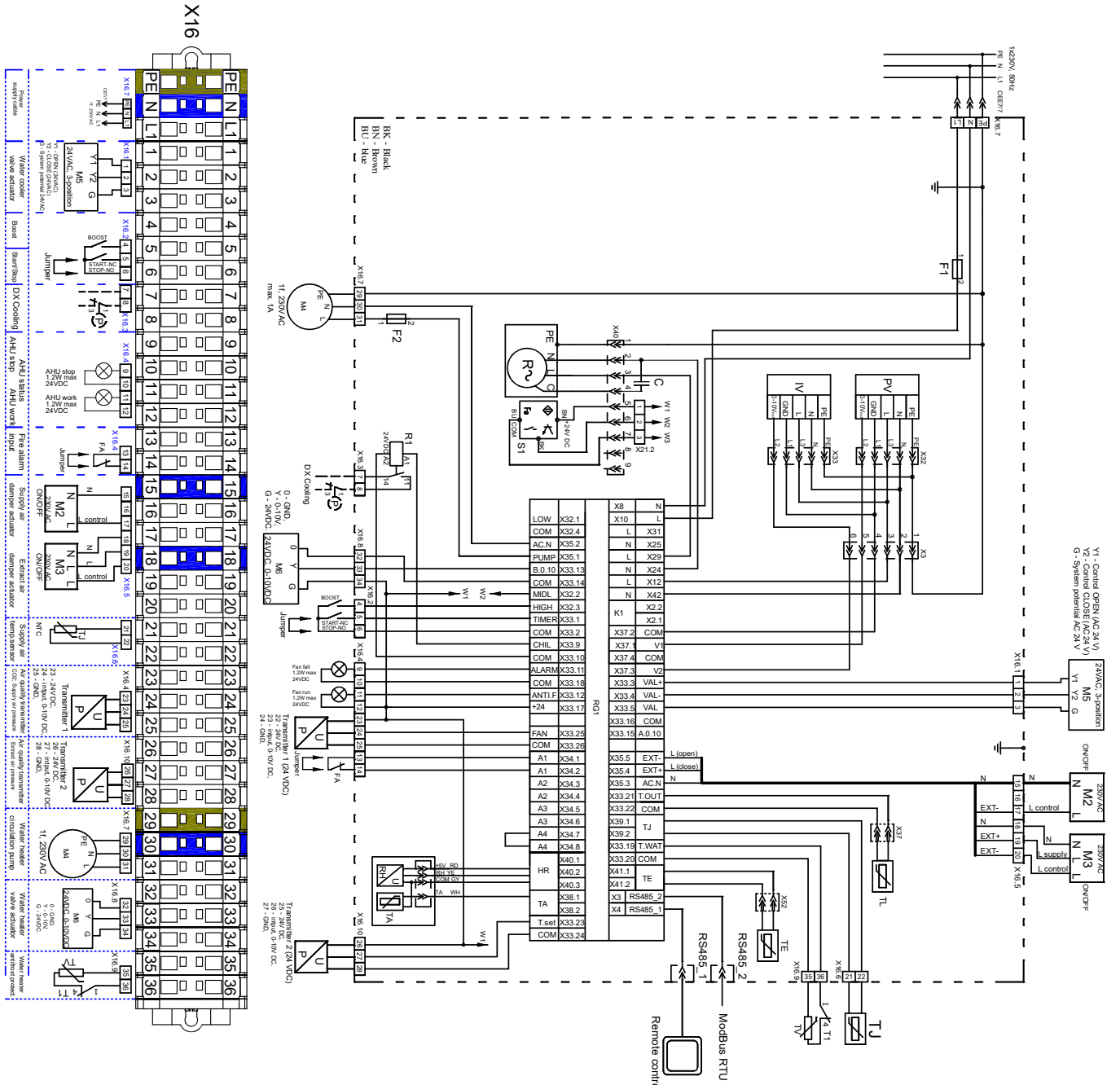

Figure 8.8.1 RIRS 400/500/700 HE EKO 3.0



- PV - supply air fan EC,
- IV - extract air fan EC,
- TJ - fresh air temperature sensor,
- TJ - supply air temperature sensor,
- DTJ100 - extract air temperature and humidity sensor,
- TE - exhaust air temperature sensor,
- T1 - antifrost thermostat,
- TV - antifrost sensor,
- R - rotor motor 6W, 230VAC,
- M2 - outside air damper actuator:
- M3 - extract air damper actuator,
- M4 - water heater circulatory pump,
- M5 - water cooler valve actuator,
- M6 - water heater valve actuator:
- P/U - "Transmitter 1" supply air pressure transmitter (0-10 VDC),
- P/U - "Transmitter 2" extract air fan 0-10V pressure, CO2 transmitters,
- FA - fire alarms input,
- RG1 - controller PRV... V2.2,
- F1 - fuse 10A (size 5x20),
- F2 - fuse 1A (size 5x20),
- C - capacitor 0.5 mF,
- S1 - rotor sensor,
- R1 - relay.

Figure 8.8.2 RIRS 400/500/700 HW EKO 3.0

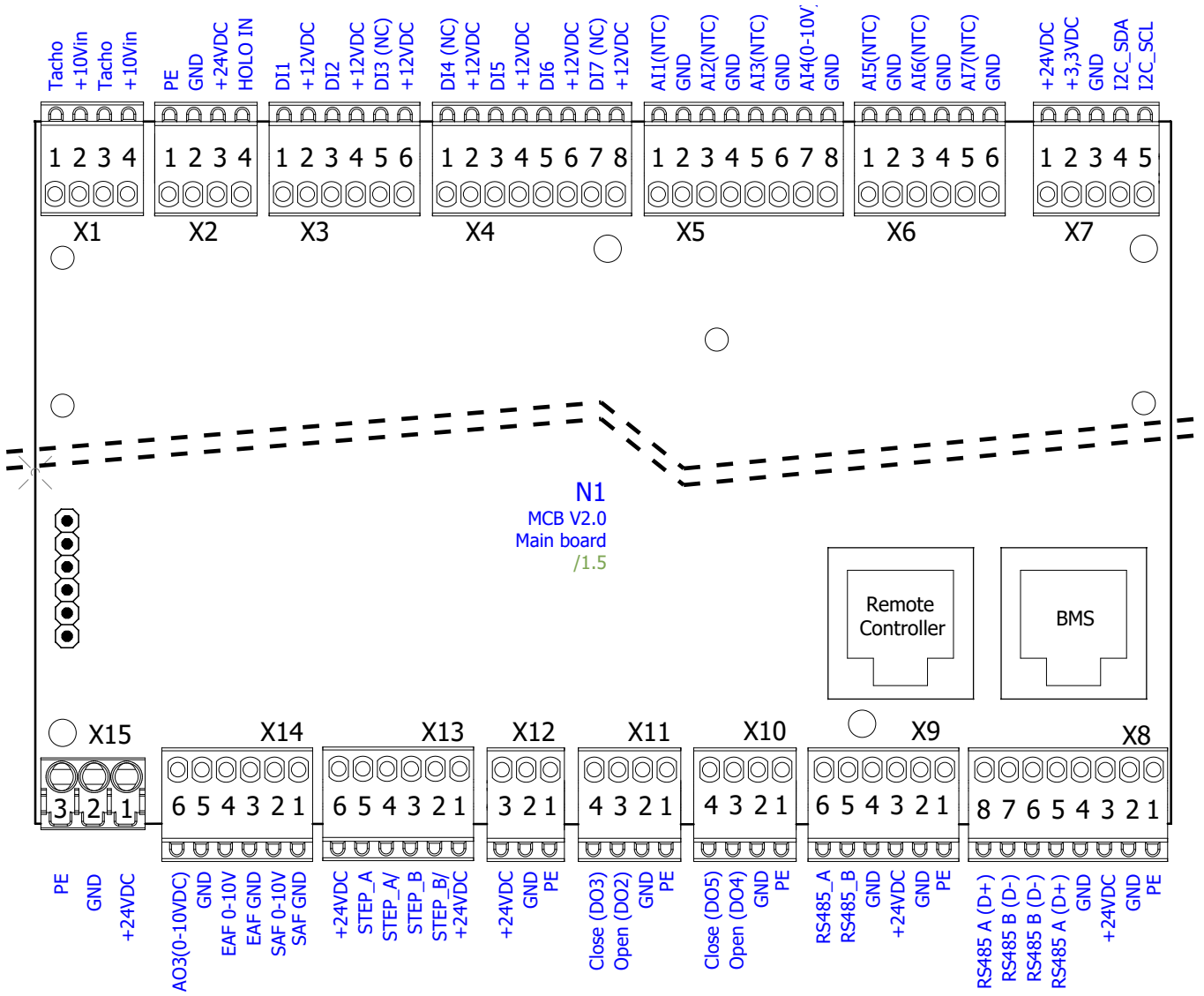

Figure 8.8.3 RIRS 500 H EKO 3.0 MCB

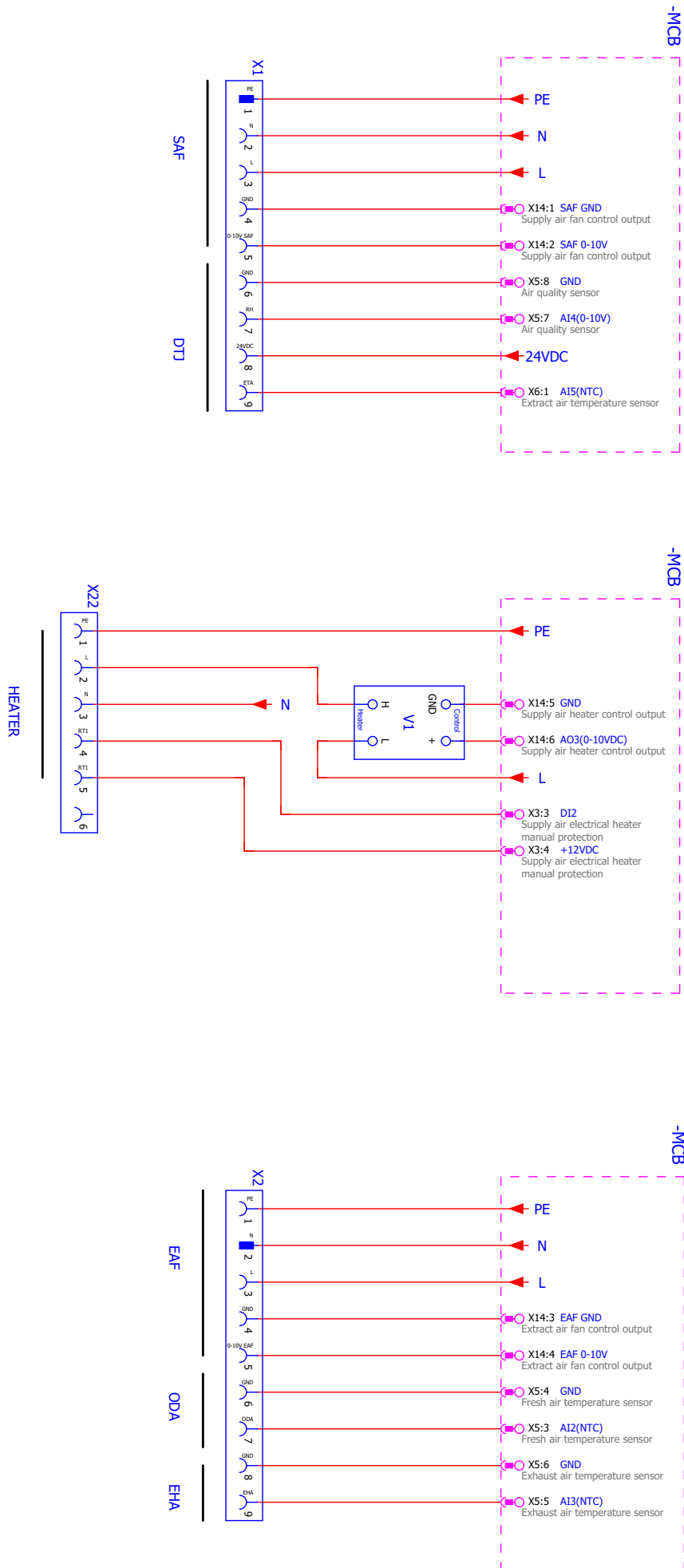

Figure 8.8.4 RIRS 500 H EKO 3.0 MCB Fans / Heater / Sensors

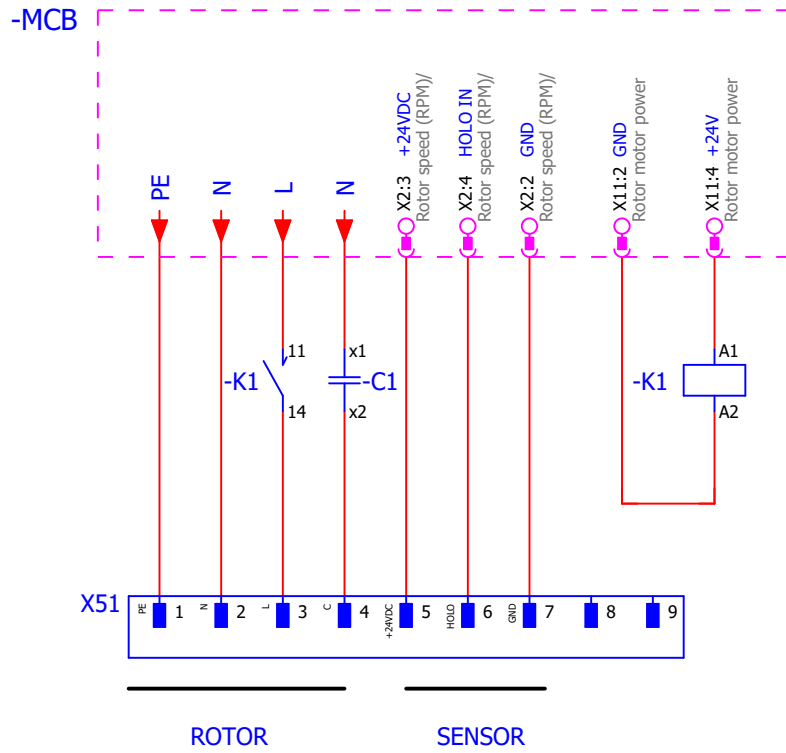

Figure 8.8.5 RIRS 500 H EKO 3.0 MCB Rotor

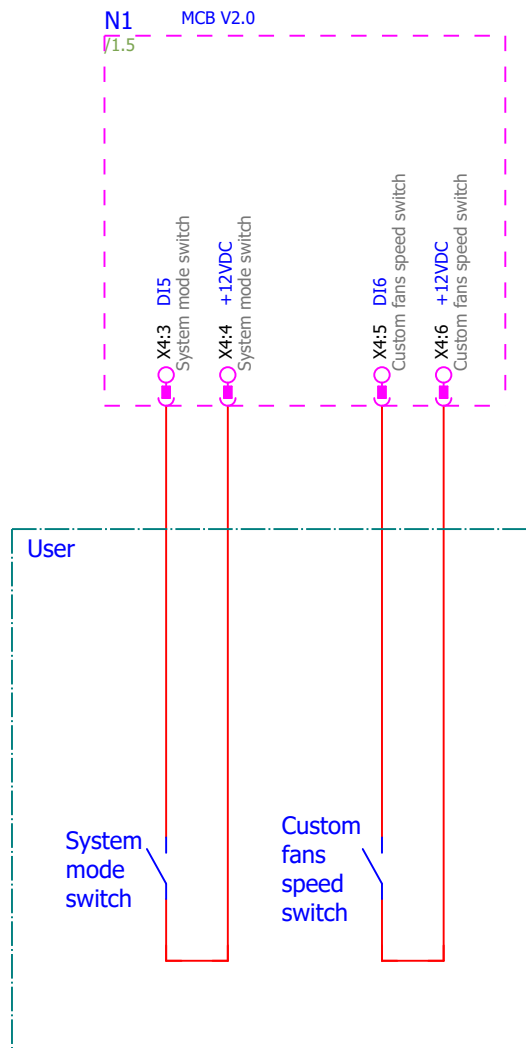

Figure 8.8.6 RIRS 500 H EKO 3.0 MCB System mode switch / Custom fans speed switch

9. POSSIBLE FAULTS AND TROUBLESHOOTING

FAILURE	CAUSE	EXPLANATION/CORRECTIVE ACTIONS
The unit is not operating	No supply voltage	Check whether the device is connected to the power network.
	Protection device is off or a current leakage relay is active (if installed by the installer)	Switch on only if the unit condition has been evaluated by a qualified electrician. If the system failed, the failure MUST BE rectified prior to switching the system on.
The air supply heater or pre-heater is not operating or malfunctioning (if installed)	Too low air flow in air ducts activates automatic protection	Check if the air filters are not clogged. Check if the fans are rotating.
	Manual protection is activated	Possible heater or unit failure. MUST contact the servicing staff for failure detection and its elimination.
Too low airflow at rated fan speed	Clogged supply and/or extract air filter(s)	Filter replacement needed
The filters are clogged and no message is shown on the remote control	Wrong time in filter timers or their switch is broken, or its pressure is set improperly.	Shorten filter timer time till the message of clogged filters appears or replace the pressure switch of the filters, or set their proper pressure.
Rotor is not rotating	Rotor belt is broken	Inspect the rotor belt. If it is broken then it should be changed or re-welded.
Rotor belt failure	Rotor belt is slipping	If belt is not broken, check its tightness and adjust, if necessary.

10. ECODESIGN DATA TABLE

Climate zone			RIRS 400 HE/HW EKO 3.0	RIRS 500 HE/HW EKO 3.0	RIRS 700 HE/HW EKO 3.0
Average	Specific energy consumption (SEC)	[kWh/m ² a]	-41,8	-41,6	-41
	SEC Class		A	A	A
	AEC	[kWh/a]	124	151	144
	AHS	[kWh/a]	4486	4535	4457
Cold	Specific energy consumption (SEC)	[kWh/m ² a]	-84,7	-84,9	-83,6
	SEC Class		A+	A+	A+
	AEC	[kWh/a]	124	151	144
	AHS	[kWh/a]	8775	8872	8719
Warm	Specific energy consumption (SEC)	[kWh/m ² a]	-17,2	-16,7	-16,5
	SEC Class		E	E	E
	AEC	[kWh/a]	124	151	144
	AHS	[kWh/a]	2028	2051	2015
Topology		Bidirectional	Bidirectional	Bidirectional	
Recovery type		Regenerative	Regenerative	Regenerative	
Type of drive (fan)		Variable	Variable	Variable	
Thermal efficiency (EN 13141-7:2010)	[%]	80	82,3	80	
Maximum airflow	[m ³ /h]	387	568	737	
Fan power at max airflow	[W]	165	263	347	
Casing sound power level (Lwa)	[dB(A)]	41	48	50	
Reference airflow	[m ³ /s]	0,08	0,11	0,14	
Reference pressure	[Pa]	50	50	50	
SPI	[W/(m ³ /h)]	0,23	0,29	0,27	
Control factor		0,65	0,65	0,65	
Declared maximum internal leakage rates	[%]	5	5	5	
Declared maximum external leakage rates	[%]	3	3	3	
Visual filter warning		Timer	Timer	Timer	
ErP Compliance		2018	2018	2018	
Internet address for disassembly instructions		https://select.salda.it			

11. DECLARATION OF CONFORMITY

Manufacturer

SALDA, UAB
Ragainės g. 100
LT-78109 Šiauliai, Lithuania
Tel.: +370 41 540415
www.salda.lt

Hereby confirms that the following products - Air handling units:

RIRS * EKO 3.0

(where by „*“ indicates possible unit installation type and modification)

Provided it was delivered and installed in the facility in accordance with the included installation instructions, comply with all applicable requirements in the following directives:

Machinery Directive 2006/42/EC
EMC Directive 2014/30/EU
Low Voltage Directive 2014/35/EU
Ecodesign Directive 2009/125/EC
RoHS 2 Directive 2011/65/EU

The following regulations are applied in applicable parts:

Ecodesign requirements for ventilation units Nr. 1253/2014
Energy labelling of residential units Nr. 1254/2014

The following harmonized standards are applied in applicable parts:

13141-7:2021 - Ventilation for buildings - Performance testing of components/products for residential ventilation - Part 7: Performance testing of a mechanical supply and exhaust ventilation units (including heat recovery) for mechanical ventilation systems intended for single family dwellings.
EN308-2022 - Heat exchangers. Test procedures for establishing performance of air to air heat recovery components.
EN ISO 12100:2012 - Safety of machinery - General principles for design - Risk assessment and risk reduction.
EN 60204-1:2018 - Safety of machinery - Electrical equipment of machines - Part 1: General requirements.
EN 60335-1:2012 - Household and similar electrical appliances. Safety. Part 1: General requirements.
EN 60529:1999/A2:2014/AC:2019 - Degrees of protection provided by enclosures (IP code).
EN 61000-6-1:2019 - Electromagnetic compatibility (EMC). Part 6-1: Generic standards - Immunity for residential, commercial and light-industrial environments.
EN 61000-6-4:2019 - Electromagnetic compatibility (EMC). Part 6-4: Generic standards - Emission standard for industrial environments.

Should any alterations be made in the products, this declaration will no longer apply.

Quality: SALDA UAB activities are in line with the international quality management system standard **ISO 9001:2015**.

Date 2024-09-02



Giedrius Taujenis
Product Manager

12. WARRANTY

1. All equipment manufactured in our factory is checked in operating conditions and tested before delivery. The test protocol is supplied together with the unit. The equipment is shipped in good working condition to the end client. The unit is warranted for the period of two years from the date of the invoice.
2. If equipment is found to have been damaged during transportation, a claim should be made against the carrier, as we assume no responsibility for such damage.
3. This warranty does not apply:
 - 3.1. when transportation, storage, installation and maintenance instructions of the unit are violated;
 - 3.2. when the equipment is improperly maintained, mounted - inadequate maintenance;
 - 3.3. when the equipment without our knowledge and permission has been upgraded or unskilled repairs were made;
 - 3.4. when the unit was used not for its original purpose.
 - 3.5. Company SALDA UAB is not responsible for potential loss of property or personal injury in cases where the Air Handling unit is manufactured without the control system and the control system is installed by the client or the third parties. The manufacturer's warranty does not cover devices that will be damaged by installing the control system.
4. This warranty does not apply to these malfunction cases:
 - 4.1. mechanical damage;
 - 4.2. damage caused by entering outside objects, materials and liquids;
 - 4.3. damage caused by natural disasters, accidents (voltage change in the electricity network, lightning, etc.).
5. The company assumes no liability for the damage to its products neither directly nor indirectly, if the damage is caused by failure to comply with the installation and mounting regulations, deliberate or careless users or third-party behaviour.

These conditions are readily discernible when the equipment is returned to our factory for inspection. If the direct client determines that equipment is found to be faulty, or a breakdown occurred, he should inform the manufacturer within five working days and deliver the equipment to the manufacturer. Delivery costs should be covered by the customer.



The manufacturer reserves the right to change this technical passport at any time without prior notice if some typographic errors or inaccurate information is found, as well as after improving the apps and/or the devices. Such changes will be included in the new issues of the technical passport. All illustrations are just for information and thus may differ from the original device. The newest manual version is available at <https://select.salda.lt>

12.1. LIMITED WARRANTY COUPON

Warranty term
24 months*

I received the complete package and technical manual of the product ready for usage. I have read the warranty terms and conditions and agree with them:

.....
 Customer's signature

*Refer to WARRANTY CONDITIONS

Dear User, we appreciate your choice and do hereby guarantee that all ventilation equipment manufactured by our Company is inspected and thoroughly tested. An operational and high-quality product is sold to the direct buyer and shipped from the territory of the factory. It is provided with a 24-month warranty from the issue date of the invoice. Your opinion is important to us, thus we always look forward to hearing your comments, feedback, or suggestions regarding technical and operational characteristics of the Products. In order to avoid any misunderstandings, please read the instructions for installation and operation of the product as well as other technical documents of the product carefully. The number of the Limited Warranty Coupon and the serial number of the product specified on the silver identification sticker attached to the housing must match. The Limited Warranty Coupon shall be valid provided that the seller's stamps and records are clear. It is not allowed to change, delete, or rewrite the data specified on it in any manner – such a coupon shall be invalid. With this Limited Warranty Coupon the manufacturer confirms his obligations to implement the imperative requirements established by effective laws on protection of consumer rights in the event of identification of any defects of the products. The manufacturer reserves the right to refuse provision of free warranty servicing in cases when the warranty conditions listed below are disregarded.

PRODUCT MAINTENANCE TABLE

Product name*		
SERIAL number*		
Installation	Interval	Date
Fan cleaning	Once per year**	
Heat-exchanger cleaning	Once per year**	
Filter replacement	Every 3-4 months**	

* - Look at the product label.

** - At least.



NOTE. The customer shall be required to complete the Product Maintenance Table.

MANUALS IN OTHER LANGUAGES

DE



https://select.salda.lt/file/rirs400_700hekode

DK



https://select.salda.lt/file/rirs400_700hekodk

FR



https://select.salda.lt/file/rirs400_700hekofr

LT



https://select.salda.lt/file/rirs400_700hekolt

NL



https://select.salda.lt/file/rirs400_700hekonl

PL



https://select.salda.lt/file/rirs400_700hekopl

RU



https://select.salda.lt/file/rirs400_700hekoru

SE



https://select.salda.lt/file/rirs400_700hekose



MAN000505

