



RIS 400-700 P EKO 3.0

EN MOUNTING AND INSTALLATION INSTRUCTION



CONTENT

2.SYMBOLS AND MARKING	3
3.SAFETY INSTRUCTIONS AND PRECAUTIONS	4
4.INFORMATION ABOUT THE PRODUCT	5
4.1. DESCRIPTION	5
4.2. DIMENSIONS AND WEIGHT	5
4.3. TECHNICAL DATA	6
4.4. OPERATING CONDITIONS	7
4.5.STANDARD PACKAGE OF COMPONENTS	7
4.6. DESCRIPTION OF COMPONENTS	7
5. INSTALLATION	8
5.1. RECEPTION OF GOODS	8
5.2. TRANSPORTATION AND STORAGE	8
5.3. UNPACKING	8
5.4.PIPING AND INSTRUMENTATION DIAGRAM	9
5.5. MOUNTING	10
5.5.1. UNIT PLACING AND MOUNTING POSITIONING REQUIREMENTS	10
5.5.2.CEILING-MOUNTING OF THE UNIT	10
5.6. CONNECTION OF THE AIR DUCT	11
5.7.CONNECTION OF THE UNIT TO ELECTRIC NETWORK	11
5.8. START-UP RECOMMENDATIONS	11
5.8.1. SYSTEM PROTECTION	11
5.8.2.PRE-STARTUP RECOMENDATIONS OF THE UNIT (IN THE PRESENCE OF THE ENDUSER)	12
6. MAINTENANCE	13
6.1. SAFETY INSTRUCTION	13
6.2.GENERAL RECOMMENDATIONS FOR THE MAINTENANCE OF VENTILATION SYSTE	13
6.3. COVER OPENING	13
6.4. FILTERS MAINTENANCE	14
6.5. FANS MAINTENANCE	14
6.6. HEAT EXCHANGER MAINTENANCE	14
6.7. HEATER MAINTENANCE	15
6.8. CONTROL BOARD MAINTENANCE	15
7. CONTROL	16
7.1. DEVICE CONTROL	16
7.2. DEVICE FUNCTIONS	16
8.CONNECTION OF ACCESSORIES	17
8.1.FIRE PROTECTION SIGNAL INPUT (FIRE PROTECTION INPUT (NC))	17
8.2. EXTERNAL CO ₂ /PRESSURE SENSORS	17
8.3.ROOM CO ₂ TRANSMITTER INSTALLATION RECOMMENDATION	17
8.4.CO ₂ CONCENTRATION ACCORDING TO PETTENKOFER LIMIT	18
8.5.CONNECTION OF SUPPLY AND EXTRACT AIR DAMPERS	18
8.6.CONNECTION OF REMOTE CONTROL PANEL OR MODBUS	19
8.7.WATER HEATER CIRCULATION PUMP AND VALVE ACTUATOR	19
8.8.RECOMMENDED SCHEME FOR CONNECTION OF INTERNAL AND EXTERNAL COMPONENTS	20
9.POSSIBLE FAULTS AND TROUBLESHOOTING	24
10.ECODESIGN DATA TABLE	25
11.DECLARATION OF CONFIMITY	26
12. WARRANTY	27
12.1. LIMITED WARRANTY COUPON	27

2. SYMBOLS AND MARKING

 **Warning – pay attention**

 **Additional information**

Apply the auxiliary label on the unit (on an easily accessible location) or on the dashed location of the technical manual in order to keep the important information about the unit.

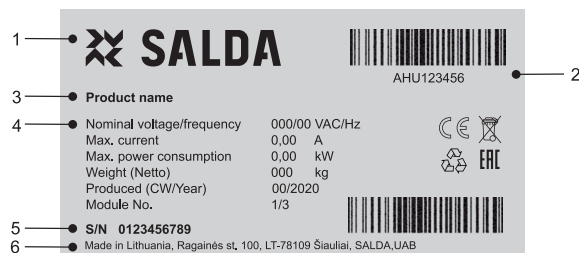

Figure 2.1. Technical label

1 - Logo; 2 - Product code (SKU); 3 - Product name; 4 - Technical data; 5 - Serial number; 6 - Production place.



Figure 2.2. Indication for duct connection.

ODA - outdoor air; SUP - supply air; ETA - extract air; EHA - exhaust air.

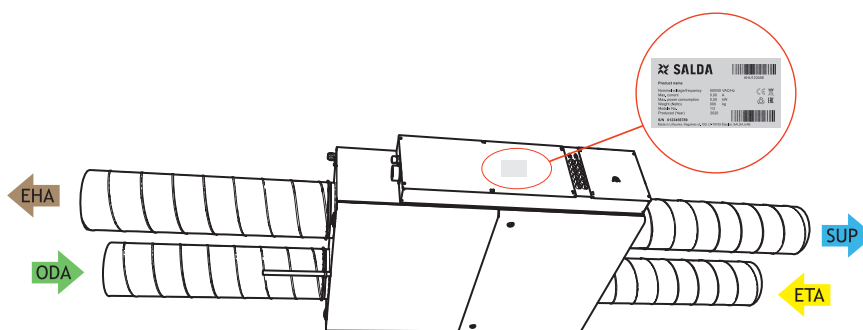



Figure 2.3. Technical label place and air duct indication

 **NOTE. Ducts are not the part of the unit.**

3. SAFETY INSTRUCTIONS AND PRECAUTIONS

Read these instructions very carefully before installing and using this equipment. Installation, connection and maintenance should be carried out by a qualified technician and in accordance with the local regulations and legislation.

The company shall take no responsibility for the injuries or damaged property if the safety requirements are not followed or the device is modified without the permission of the manufacturer.

Main safety rules

Danger

- Before carrying out any electrical or maintenance works, make sure that the device is disconnected from the mains and all moving parts of the device have stopped.
 - Make sure that the fans are not accessible through air ducts or branch openings.
 - If any liquids on electric parts or connections that bear voltage are noticed, stop the operation of the device.
 - Do not plug the device into the mains that differ from the one indicated on the label or on the housing.
 - Voltage of the mains should comply with the electro technical parameters indicated on the label.
 - The device should be earthed in accordance with the regulations on the installation of electric devices. Turning on and using unearthed device is not allowed. Follow the requirements specified on the device's labels that indicate danger.
-

Warnings

- Connection of electricity and maintenance of the device should be performed by the qualified personnel only and in accordance with the manufacturer's instructions and safety requirements.
 - In order to reduce the risk during installation and maintenance, suitable protective clothing must be worn.
 - Beware of sharp angles while carrying out installation and maintenance works.
 - Do not touch heating elements until they haven't cooled down.
 - Some devices are heavy, you should be very careful while transporting and installing them. Use suitable lifting equipment.
 - When connecting electricity to the mains, a circuit breaker of suitable size must be used.
-

Warning!

- If the device is installed in a cold environment, make sure that all connections and tubes are properly isolated. Intake and discharge air ducts should be isolated in all cases.
 - Openings of the ducts should be covered during transportation and installation.
 - Make sure not to damage the heater when connecting the piping of the water heater. For tightening up, use a wrench/spanner.
-

Before starting up the device

- make sure, that there are no strange objects inside;
 - manually check fans to make sure they are not stuck or blocked;
 - if rotary heat exchanger is installed in the device, make sure that it is not stuck or blocked;
 - check the earthing;
 - make sure that all components and accessories are connected in accordance with the wiring diagram or provided instructions.
-

4. INFORMATION ABOUT THE PRODUCT

4.1. DESCRIPTION

RIS P EKO 3.0 is a residential air handling unit with a high efficiency (up to 82 %) counterflow heat exchanger. The unit supplies ventilation in home and takes the heat from exhaust air. AHU complies with ErP 2018 requirements. The unit is operated by a separate remote control panel or through separate MB-Gateway by PC. Remote control panel and MB-Gateway are optional and not included in standard package.



Not suitable for operation in pools, saunas and other similar premises.

4.2. DIMENSIONS AND WEIGHT

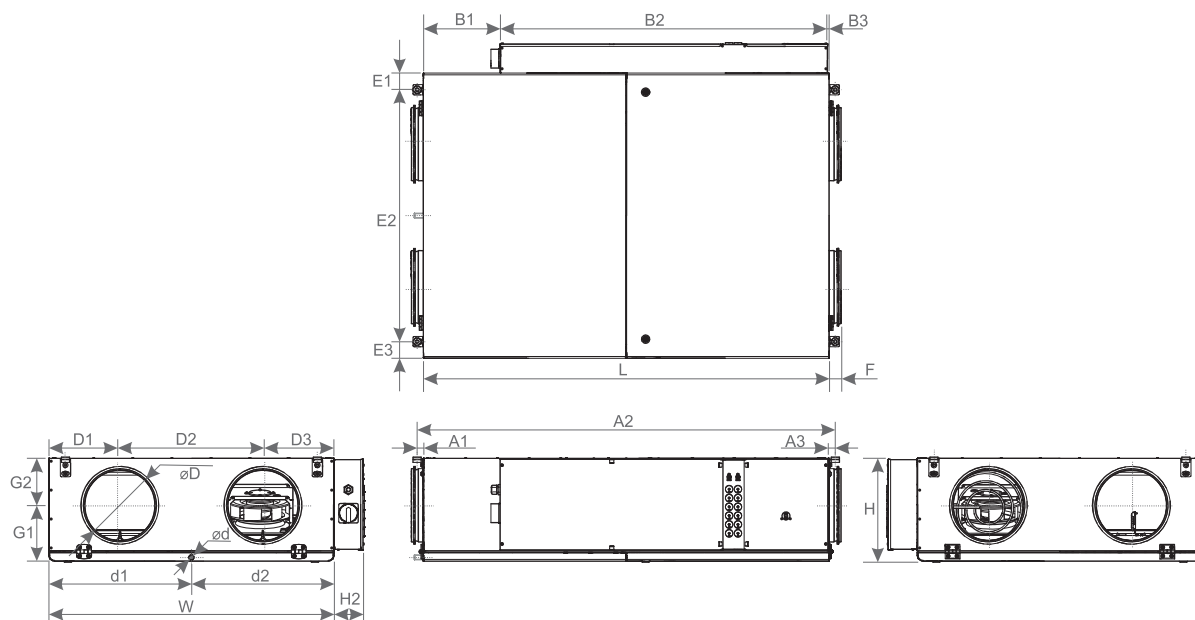

RIS EKO 3.0		400 PE 0.9	400 PE 1.6	400 PE 3.0	400 PW	700 PE 1.2	700 PE 3.0	700 PE 4.5	700 PW
L	[mm]	1300	1300	1300	1300	1380	1380	1380	1380
W	[mm]	670	670	670	670	970	970	970	970
H	[mm]	330	330	330	330	350	350	350	350
D	[mm]	200	200	200	200	250	250	250	250
H2	[mm]	100	100	100	100	99	99	99	99
F	[mm]	31	31	31	31	41	41	41	41
d	[mm]	16	16	16	16	16	16	16	16
A1	[mm]	143	143	143	143	21	21	21	21
A2	[mm]	1014	1014	1014	1014	1422	1422	1422	1422
A3	[mm]	143	143	143	143	21	21	21	21
E1	[mm]	21	21	21	21	57	57	57	57
E2	[mm]	712	712	712	712	856	856	856	856
E3	[mm]	21	21	21	21	57	57	57	57
B1	[mm]	181	181	181	181	262	262	262	262
B2	[mm]	770	770	770	770	1113	1113	1113	1113
B3	[mm]	350	350	350	350	5	5	5	5
d1	[mm]	335	335	335	335	485	485	485	485
d2	[mm]	335	335	335	335	485	485	485	485
D1	[mm]	183	183	183	183	242	242	242	242
D2	[mm]	304	304	304	304	486	486	486	486
D3	[mm]	183	183	183	183	242	242	242	242
G1	[mm]	183	183	183	183	190	190	190	190
G2	[mm]	147	147	147	147	160	160	160	160
WEIGHT	[kg]	69	70	71	67	75	76	77	72

4.3. TECHNICAL DATA

RIS EKO 3.0		400PE 0.9	400PE 1.6	400PE 3.0	400PW
Exhaust air fan					
phase/voltage	[50 Hz/VAC]	1/230	1/230	1/230	1/230
power/current	[kW/A]	0,09/0,73	0,09/0,73	0,09/0,73	0,09/0,73
speed	[min ⁻¹]	3230	3230	3230	3230
control input	[VDC]	0-10	0-10	0-10	0-10
protection class		IP54	IP54	IP54	IP54
Supply air fan					
phase/voltage	[50 Hz/VAC]	1/230	1/230	1/230	1/230
power/current	[kW/A]	0,09/0,73	0,09/0,73	0,09/0,73	0,09/0,73
speed	[min ⁻¹]	3230	3230	3230	3230
control input	[VDC]	0-10	0-10	0-10	0-10
protection class		IP54	IP54	IP54	IP54
Integrated electrical heater	[kW]	0,9	1,6	3,0	-
Total power/current consumption	[kW/A]	1,07/5,5	1,77/8,5	3,17/14,5	0,17/1,5
Automatic control integrated		PRV	PRV	PRV	PRV
Insulation of walls	[mm]	30	30	30	30
Exhaust air filter (class, dimensions LxWxH)	[mm]	MPL 300x220x46 ePM10 55%	MPL 300x220x46 ePM10 55%	MPL 300x220x46 ePM10 55%	MPL 300x220x46 ePM10 55%
Supply air filter (class, dimensions LxWxH)	[mm]	MPL 300x220x46 ePM1 70%	MPL 300x220x46 ePM1 70%	MPL 300x220x46 ePM1 70%	MPL 300x220x46 ePM1 70%
Device protection class		IP34	IP34	IP34	IP34
RIS EKO 3.0					
		700PE 1.2	700PE 3.0	700PE 4.5	700PW
Exhaust air fan					
phase/voltage	[50 Hz/VAC]	1/230	1/230	1/230	1/230
power/current	[kW/A]	0,17/1,4	0,17/1,4	0,17/1,4	0,17/1,4
speed	[min ⁻¹]	3230	3230	3230	3230
control input	[VDC]	0-10	0-10	0-10	0-10
protection class		IP54	IP54	IP54	IP54
Supply air fan					
phase/voltage	[50 Hz/VAC]	1/230	1/230	1/230	1/230
power/current	[kW/A]	0,17/1,4	0,17/1,4	0,17/1,4	0,17/1,4
speed	[min ⁻¹]	3230	3230	3230	3230
control input	[VDC]	0-10	0-10	0-10	0-10
protection class		IP54	IP54	IP54	IP54
Integrated electrical heater	[kW]	1,2	3,0	4,5	-
Total power/current consumption	[kW/A]	1,54/8,34	3,34/15,84	4,84/9,34	0,34/2,84
Automatic control integrated		PRV	PRV	PRV	PRV
Insulation of walls	[mm]	30	30	30	30
Exhaust air filter (class, dimensions LxWxH)	[mm]	MPL 445x210x46 ePM10 55%	MPL 445x210x46 ePM10 55%	MPL 445x210x46 ePM10 55%	MPL 445x210x46 ePM10 55%
Supply air filter (class, dimensions LxWxH)	[mm]	MPL 445x210x46 ePM1 70%	MPL 445x210x46 ePM1 70%	MPL 445x210x46 ePM1 70%	MPL 445x210x46 ePM1 70%
Device protection class		IP34	IP34	IP34	IP34

Acoustic data: check the product page on www.salda.it



Not suitable for installation in living rooms: additional noise insulation required.

4.4. OPERATING CONDITIONS

RIS EKO 3.0	400 PE 0.9	400 PE 1.6	400 PE 3.0	400 PW	700 PE 1.2	700 PE 3.0	700 PE 4.5	700 PW
Minimum outdoor air temperature	-2 °C	-2 °C	-2 °C	-2 °C	-2 °C	-2 °C	-2 °C	-2 °C
Maximum outdoor air temperature	+40 °C	+40 °C	+40 °C	+40 °C	+40 °C	+40 °C	+40 °C	+40 °C
Minimum extracted air temperature	+15 °C	+15 °C	+15 °C	+15 °C	+15 °C	+15 °C	+15 °C	+15 °C
Maximum extracted air temperature	+40 °C	+40 °C	+40 °C	+40 °C	+40 °C	+40 °C	+40 °C	+40 °C
Maximum extracted air relative humidity	60%	60%	60%	60%	60%	60%	60%	60%
Minimum ambient air temperature	+5 °C	+5 °C	+5 °C	+5 °C	+5 °C	+5 °C	+5 °C	+5 °C
Maximum ambient air temperature	+40 °C	+40 °C	+40 °C	+40 °C	+40 °C	+40 °C	+40 °C	+40 °C
Installation	indoor	indoor	indoor	indoor	indoor	indoor	indoor	indoor

4.5. STANDARD PACKAGE OF COMPONENTS

RIS P EKO 3.0	400 PE 0.9	400 PE 1.6	400 PE 3.0	400 PW	700 PE 1.2	700 PE 3.0	700 PE 4.5	700 PW
Key 291103	1	1	1	1	1	1	1	1
Hose 16x20 Cristal transparent	300 mm	300 mm	300 mm	300 mm	300 mm	300 mm	300 mm	300 mm
Clamp with handle 16/27	1	1	1	1	1	1	1	1
Washer 5 R DIN440	8	8	8	8	8	8	8	8
Washer spring 5 DIN127	8	8	8	8	8	8	8	8
Bolt 5x20 DIN7895	8	8	8	8	8	8	8	8
Bracket 1	4	4	4	4	4	4	4	4
Anti-vibration rubber 313508000	4	4	4	4	4	4	4	4

4.6. DESCRIPTION OF COMPONENTS

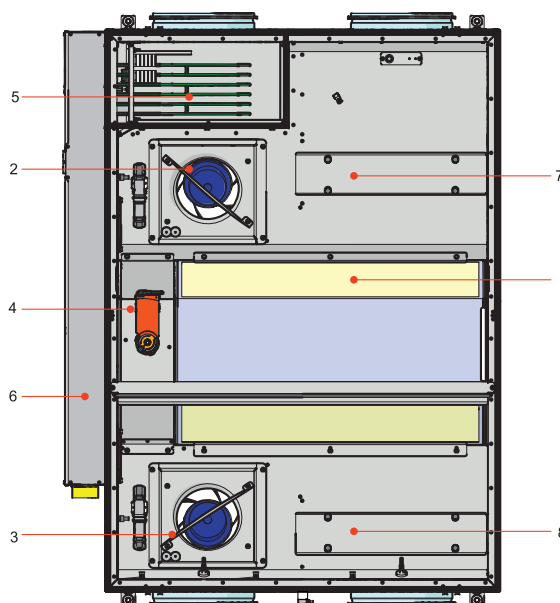

1 - Plate heat exchanger; 2 - Supply fan; 3 - Exhaust fan; 4 - By-pass damper; 5 - Electrical heater; 6 - Control board; 7 - Extract air filters (panel); 8 - Supply air filter (panel).

5. INSTALLATION

5.1. RECEPTION OF GOODS

Each device is carefully checked before transportation. When receiving the goods, checking the devices for any damage made during transportation is recommended. If any damage to the unit is observed, immediately contact the representatives of a transport company. Please inform the representative of the manufacturer, if any deviation of the device is noticed.

5.2. TRANSPORTATION AND STORAGE

- All units are factory-packaged to withstand normal conditions of transportation.
- When unpacking, check the unit for any damage made during transportation. Installing of damaged units is not allowed!
- The packaging is used for protection purpose only!
- When unloading and storing the units, use suitable lifting equipment to avoid damage and injuries. Do not lift units by holding on power supply cables, connection boxes, air extract or exhaust flanges. Avoid hits and shock overloads. Before installation, the units must be stored in a dry room with the relative air humidity not exceeding 70% (at +20°C) and with an average ambient temperature ranging between +5 °C and +30 °C. The storage place must be protected against dirt and water.
- The units must be transported to the storage place or installation site using forklifts.
- The recommended storage period should not be longer than one year. In case of storing the units for a period longer than one year, checking if the fan bearings and motor rotate without difficulty (turning the impeller by hand) and if the electric circuit insulation is not damaged or the moisture has not accumulated must be performed before the installation of the unit.

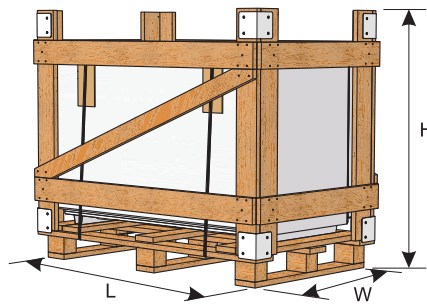

	H	W	L	MAX. NUMBER OF TRANSPORTED PACKAGES
	[mm]	[mm]	[mm]	[pcs.]
RIS EKO 3.0				
400 PE 0.9	595	875	1465	1
400 PE 1.6	595	875	1465	1
400 PE 3.0	595	875	1465	1
400 PW	595	875	1465	1
700 PE 1.2	625	1185	1570	1
700 PE 3.0	625	1185	1570	1
700 PE 4.5	625	1185	1570	1
700 PW	625	1185	1570	1

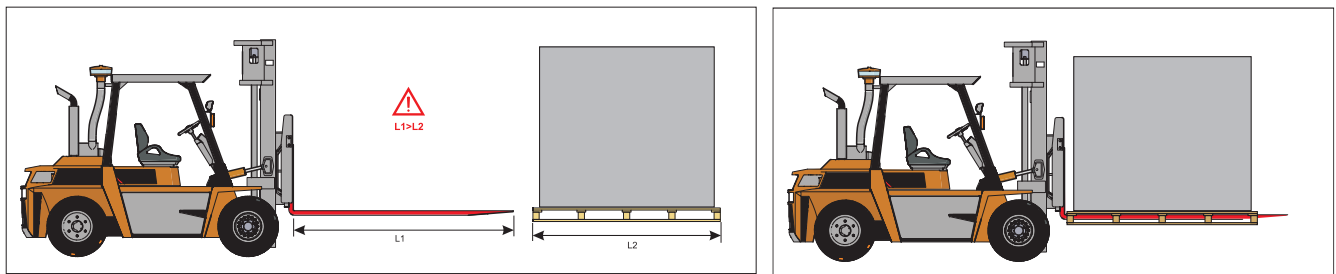

Figure 5.2.1. Lifting by forklift.



In order to prevent damage to the casing, only a product placed on a pallet should be lifted.

5.3. UNPACKING



Accessories may be packed together with the product. Prior to transporting the unit, the accessories should be unpacked first.

- Remove the film from the unit.
- Remove the bracing packaging tape that keeps the protective profiles in place.
- Remove the protective profiles.
- After unpacking the unit, examine it to make sure that no damage was made during transportation. Installing of damaged units is not allowed!
- Before commencing the installation of the unit, please check if all ordered equipment have been delivered. Any variation from the ordered equipment list must be reported to the product supplier.

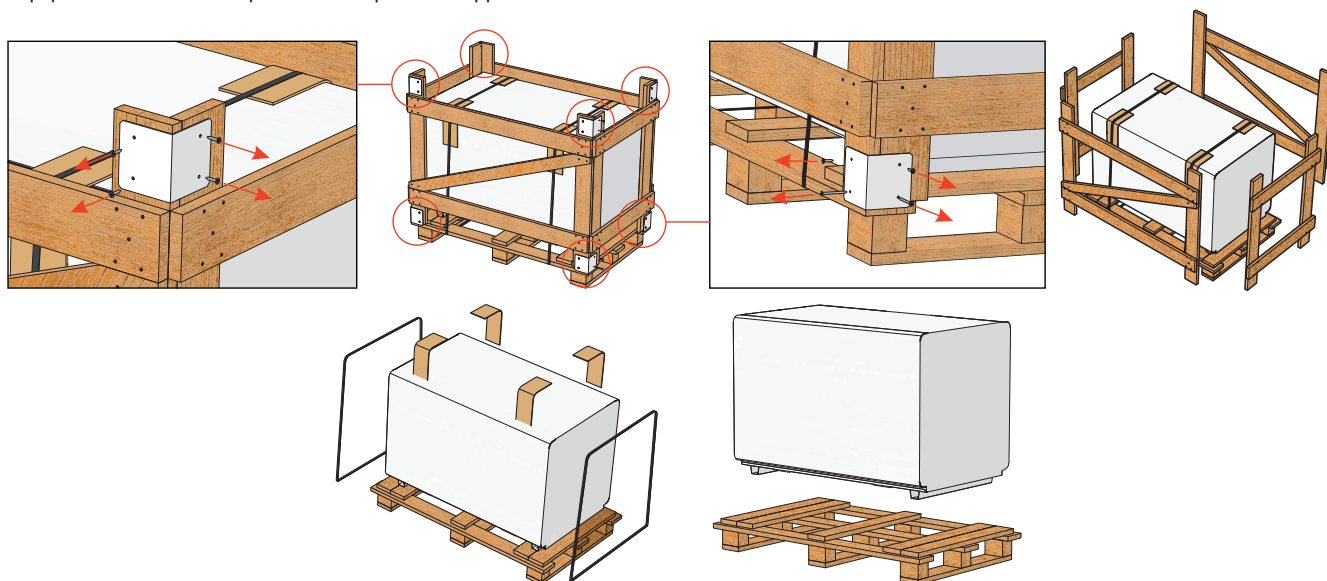

5.4. PIPING AND INSTRUMENTATION DIAGRAM

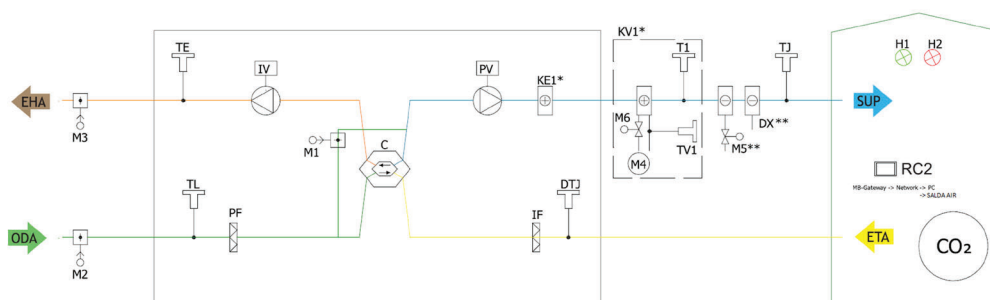

* KE1 - only in electrical version; * KV1 - used in water version; ** Possible to control.

THE LIST OF COMPONENTS

C	Plate heat exchanger	PV	Supply air fan
IF	Extract air filter	PF	Supply air filter
IV	Exhaust fan	TE	Exhaust air temperature sensor
TJ	Supply air temperature sensor	DTJ	Extract air temperature and humidity sensor
CO₂	CO ₂ sensor	PC	Computer
KE1	Electric heater*	M1	By-pass damper
M2	Outdoor air damper actuator	M3	Exhaust air damper actuator
TL	Outdoor air temperature sensor	MB-Gateway	Network module
	Ventilated premises	NET	Network
DX	DX cooler	KV1	Water heater*
T1	Water heater thermostat*	M4	Water heater circulation pump*
M5	Water cooler valve motor	RC2	Stouch, Flex or ST-SA-Control remote control panel
M6	Water heater valve motor*	TV1	Water heater temperature sensor *

* Component/possibility to connect it depends on model.

POSSIBLE PCB INPUTS/OUTPUTS

FA	Fire alarm	H1	Working indication output
	Fans speed switch (BOOST)	H2	Alarm indication output
	System mode switch (START/STOP)		

5.5. MOUNTING

- Installation should be carried out by qualified and trained staff only.
- When connecting air ducts, consider the labels on the casing of the unit.
- Before connecting to the air duct system, the connection openings of ventilation unit should be closed.
- When connecting the ducts, the air-flow direction indicated on the device housing should be observed.
- Do not connect the bends close to connection flanges of the unit. The minimum distance of the straight air duct between the unit and the first branch of the air duct in the supply air duct must be $1xD$, in air exhaust duct $3xD$, where D is the diameter of the air duct.
- It is recommended to use the brackets (accessories). This will reduce the vibration transmitted by the unit to the air duct system and environment.
- Sufficient space must be provided for opening of the manhole and filter covers.
- If the ventilation unit is wall-mounted wall, it may transmit noise vibrations to the premises. Though the level of noise generated by the fans is admissible, mounting the unit at the distance of 400 mm from the nearest wall is recommended. Where this is not possible, mounting of the unit on the wall of the room where the level of noise is not significant is recommended.
- Ducts are connected to the unit in such way that they could be easily disassembled and the heater could be removed from the unit when carrying out maintenance, servicing and/or repairs



The protective film is used to protect the unit during transportation. It is recommended to remove the film; otherwise, oxidation signs may occur.



Before every heating season the condensate tube shall be filled with water as indicated during the first start-up!

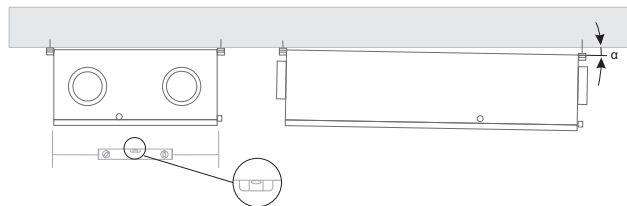

Ceiling-mounting positions ($\alpha > 1^\circ$)

5.5.1. UNIT PLACING AND MOUNTING POSITIONING REQUIREMENTS

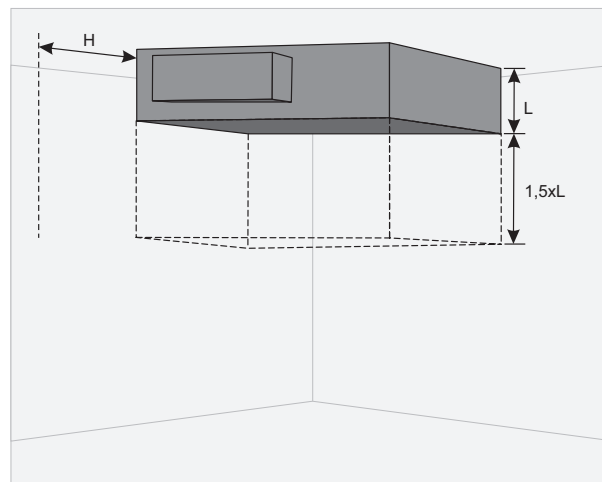

Min. distance to open the door - $1,5xL$; Min. distance to open the control box door - $H > 400$ mm.

5.5.2. CEILING-MOUNTING OF THE UNIT

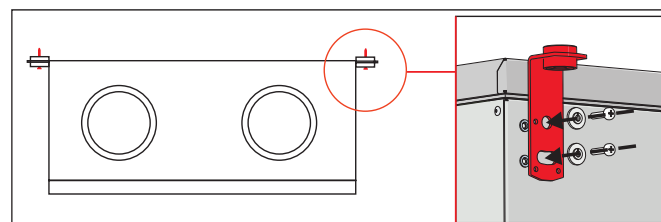

Figure 5.5.3. Ceiling-mounting positions

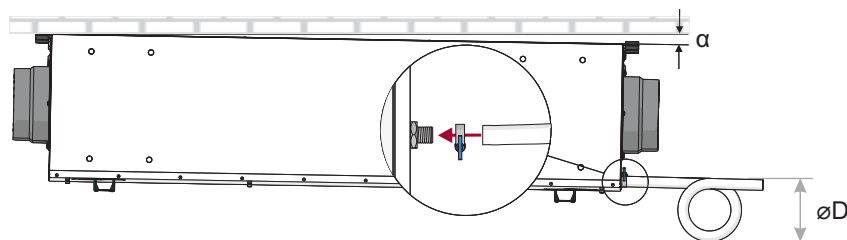

Figure 5.5.4. Drainage system installation (øD=150 mm)

The system should be connected to the pipe in the following order: AHU, siphon and sewerage system. The pipe should have at a 3° degree slope (1 meter of pipe must be have a 55 mm slope downwards)! Before turning on AHU, the draining system should be filled up with at least 0.5 l of water (siphon must be always filled with water), also check if water reaches sewerage system! Otherwise, the premises can be flooded. Draining system must be installed in the premises where the temperature is not lower than 0°C. If the temperature falls below 0°C, the draining system should be insulated with thermal insulation.

5.6. CONNECTION OF THE AIR DUCT

- The connected air ducts must not be bent and have separate fixing.
- Make sure that the fans can not be accessed through air duct heads. Otherwise, protective grid should be installed. You may choose the grid from the range of products provided in our website.
- Do not reduce the diameter of the piping near air inlet or exhaust ducts. If you want to reduce the airflow speed in the system, drop of pressure and noise level, you can increase the diameter.
- In order to reduce the level of the noise in the air supply system, install dampers (see the chapter on air supply system installation).
- In order to reduce air loss in the system, the air ducts and profile components should be of class C and higher. The catalog on the above-mentioned items can be found in our website.
- External air and exhaust system piping should be isolated in order to prevent heat loss and condensation.
- Maintaining the distance of up to 8 meters between air intake and air exhaust ducts is recommended. Air supplying system should be installed away from potential air pollution sources.
- When installing air ducts next to the ventilation equipment, brackets must be used. They suppress vibration and assure secure installation of the various system parts. The necessary brackets can be found in our catalog or website.
- Air ducts are often mistakenly connected in inappropriate location. The ventilation units bear the labels indicating the correct air duct connection layout. Before starting up the system, carefully check if all related works have been performed properly.



For flange diameters see chapter " DIMENSIONS AND WEIGHT".

5.7. CONNECTION OF THE UNIT TO ELECTRIC NETWORK

- Supply voltage to the unit must be connected by a qualified specialist following the manufacturer's instructions and applicable safety guidelines.
- The unit's power network voltage must correspond to electro technical specifications of the unit indicated in the technical decal.
- The unit's voltage, power and other technical specifications are provided in the unit's technical decal (on the unit casing). The unit must be connected to the voltage plug socket of the grounded power network in accordance with the applicable requirements.
- The unit must be earthed according to electrical equipment installation regulation.
- Using extension wires (cables) and power network plug socket distribution devices is not allowed.
- Prior to carrying out any ventilation unit installation and connection works (before the unit is commissioned), the unit must be disconnected from the power network.
- After installation of the ventilation unit, the power network plug socket must be accessible at any time. If the unit is equipped with circuit breaker, disconnection from the power network is performed through the two-pole or four-pole circuit breaker (by disconnecting phase poles and neutral).
- Before it is connected to the power network, the unit must be carefully checked for any damage (execution, control, and measurement nodes) made during transportation.
- The power cable can be replaced only by a qualified technician, having evaluated the rated power and current.



The manufacturer does not assume any liability for personal injuries and property damage due to nonconformance with the provided instructions.

5.8. START-UP RECOMMENDATIONS

5.8.1. SYSTEM PROTECTION

The control board of the unit is equipped with the following integrated devices for the protection against short circuit:

	RIS EKO 3.0	400PE 0.9	400PE 1.6	400PE 3.0	400PW	RIS EKO 3.0	700PE 1.2	700PE 3.0	700PE 4.5	700PW
F1 (Q2)	16 A	16 A	16 A	5 A	F1	5 A	5 A	5 A	5 A	5 A
F2 (Q3)	10 A	10 A	16 A	1 A	F2 (Q2)	6 A	16 A	10 A	1 A	

It is recommended to use the unit with external electrical protection device.

RIS EKO 3.0	400PE 0,9	400PE 1,6	400PE 3,0	400PW	700PE 1,2	700PE 3,0	700PE 4,5	700PW
Mains Fuse	10 A	16 A	25 A	6 A	16 A	25 A	16 A	6 A



To ensure safe maintenance of the unit, it is necessary to turn off main switch and/or external protection device.

5.8.2. PRE-STARTUP RECOMENDATIONS OF THE UNIT (IN THE PRESENCE OF THE ENDUSER)

Prior to start-up, the system must be carefully cleaned. Check for the following:

- operation systems and unit elements as well as automation and automation devices were not damaged during installation,
- all electrical devices are connected to power supply and fit for service,
- all necessary automation elements are installed and connected to power supply and terminal blocks,
- cable connection to terminal blocks comply with the existing wiring diagrams,
- all electrical equipment protection components are properly connected (if they are additionally used),
- cables and wires correspond to all applicable safety and functional requirements, diameters, etc.,
- earthing and protection systems are properly installed,
- condition of all seals and sealing surfaces is proper.

6. MAINTENANCE

6.1. SAFETY INSTRUCTION



Unplug the unit from the mains before opening the door (disconnect the power plug from the outlet or in case a automatic circuit breaker installed, disconnect it as well. Make sure that it cannot be turned on by third parties) and wait until the fans completely stop (for about 2 min.).

6.2. GENERAL RECOMMENDATIONS FOR THE MAINTENANCE OF VENTILATION SYSTE

In order to ensure proper functioning of the system, maintenance requirements and its periods should be observed. Otherwise, the warranty shall be void. Some recommendations are provided in the table below, but they are just advisory, as the need for system maintenance depends on the location of the unit installation, the pollution of atmosphere, population, working hours, etc.

COMPONENT	DURING START-UP	AT LEAST EVERY 6 MONTHS
Filters	Check the cleanliness of the filters	Replace filters every 3 to 4 months or according to the control device indications. Check cleanliness. Clean, if necessary Make sure that the impellers are not unbalanced.
Fans	Check the connections and the direction of rotation	Make sure that the impellers do not cause noise when rotated by hand. Make sure that the fastening screws are not loose and free of mechanical damage. Check electrical connections and make sure that these are se-cured properly and are free of signs of corrosion.
Plate Heat exchanger	Check the cleanliness of the heat exchanger	Check cleanliness and clean, if necessary
Control panel	Check the connections	Check the connections
Electric heater	Check the connections	Clean off dust, and check the electrical components and connec-tions of the heater
Presure sensor	Check electrical connections	Check the operation
Temperature sensor	Check electrical connections	Check the operation
Air intake and discharge system	Check the connections	Clean
Air duct system	Check the tightness	Clean
Dampers, diffusers, grid	Check the tightness of connections	Clean
Switching unit (contactor)		Every 3 to 4 months, visually assess the functioning of the switch-ing unit (contactor), i.e. make sure that its casing has no signs of melting or is not thermally damaged otherwise and does not produce any unusu-al sounds. All the contactors in the product or in its accessories must be checked.
Condensate trap and discharge assembly	Check the condensate discharge assembly and make sure that wa-ter runs from the bath properly.	Clean

6.3. COVER OPENING

Before opening the covers, first, unplug the unit from the mains, then wait for 2 minutes (until the fans completely stop).

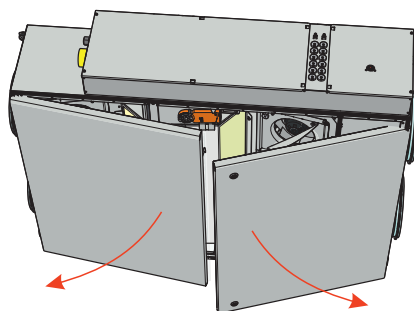

6.4. FILTERS MAINTENANCE

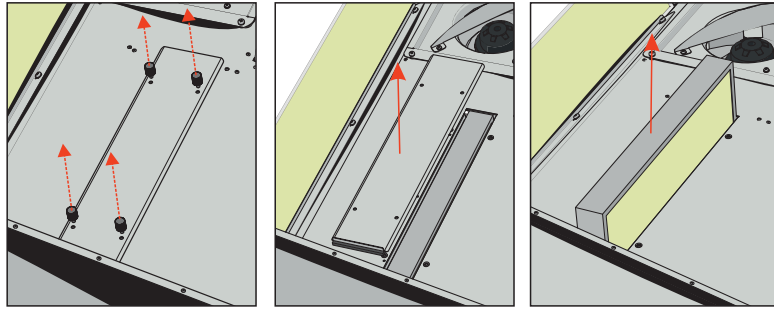

In order to remove the filters, open unit door and take off the filters.

Dirt increases air resistance in the filter, therefore, lower amount of air is supplied into the premises. Arrows on the filters must comply with airflow direction.



**After changing the filters, please reload the filter timer. The instruction on reloading can be found in the control panel operation manual or on our website www.salda.it
Operation of the unit without filters is not allowed.**



Change the filters every 3-4 months or according to the notification on the control device.

6.5. FANS MAINTENANCE

- Fan maintenance should be performed by experienced and trained staff only.
- The fan should be inspected and cleaned at least once per year.
- Prior to commencing any maintenance or repairs, make sure the fan is disconnected from the power source.
- Proceed to maintenance and repair after any fan rotation is stopped.
- Observe staff safety regulations during maintenance and repairs.
- The motor features a heavy-duty ball bearing design. The motor is completely sealed and grease-free.
- Detach the fan from the unit.
- The impeller should be particularly checked for built-up material or debris that may cause an imbalance. Excessive imbalance may lead to accelerated wear on motor bearings and vibration.
- Clean impeller and inside housing with mild detergent, water and damp, soft cloth.
- Do not use high-pressure cleaner, abrasives, sharp tools or caustic solvents that may scratch or damage the housing and impeller.
- Do not plunge the motor into any fluid while cleaning the impeller. Make sure the impeller's balance weights are not moved.
- Make sure the impeller is free of any obstacles.
- Install the fan back into the unit. Connect fan power and control signals.
- In case the fan after maintenance does not automatically start up or stop, contact the manufacturer. Malfunction of the fan can be identified by the pressure in the system (when pressure switches are connected). In case of any fault in the fan motor, a notice will appear on the control panel.



Prior to commencing any maintenance or repairs, make sure the unit is disconnected from the power source.

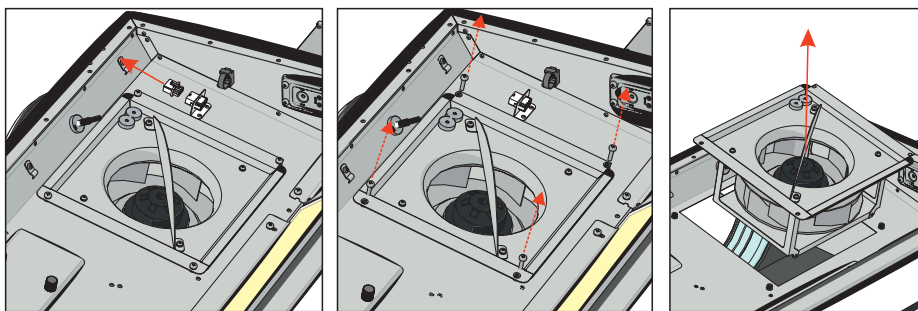

6.6. HEAT EXCHANGER MAINTENANCE

- Be sure to disconnect the unit from power source before performing any maintenance or repair.
- Proceed to maintenance and repair after any rotation in the fan stopped.
- Clean the heat exchanger once a year.
- Firstly take out heat exchanger cassette carefully. Submerge it into a bath and wash with warm soapy water (do not use soda). Then rinse it with weak hot water stream (too strong stream can fold the plates). Place back the heat exchanger only when it is completely dry.

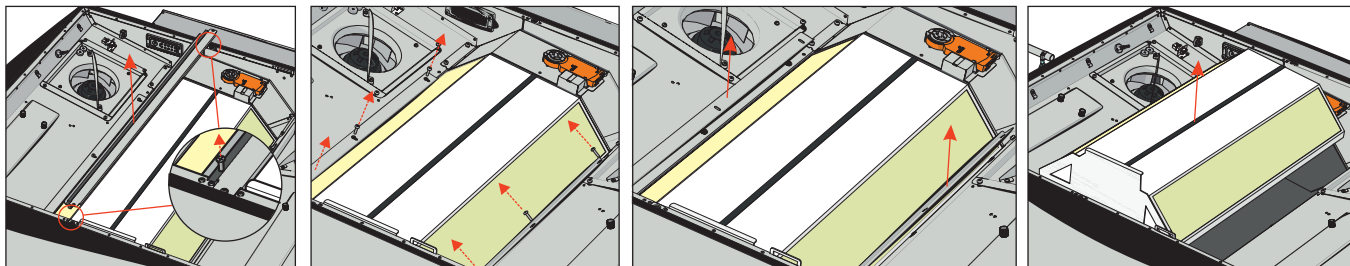

CAUTION: the heat exchanger can not be used when the filters are removed!

6.7. HEATER MAINTENANCE

- In case manual protection is activated, check for a fault before pressing the RESET button. If the fault is identified after it has been rectified, press the RESET button using a screwdriver or a similar object.
- Electrical heater does not require additional servicing. The filters must be replaced as described above.
- Heaters are equipped with 2 thermal protection devices: an automatic self-resetting protection device that is activated at +50 °C, and a manually restored protection device that is activated at +100 °C.
- After an activation of the manually restored protection device, make sure the unit is disconnected from the power supply. Wait until all heating elements cool down and the fans completely stop. Having identified and rectified the failure, to start the unit, press the RESET button. The failure can be identified by a qualified technician only.
- If necessary, electric heater can be removed. Disconnect the electrical connector from the heater and remove the heater.

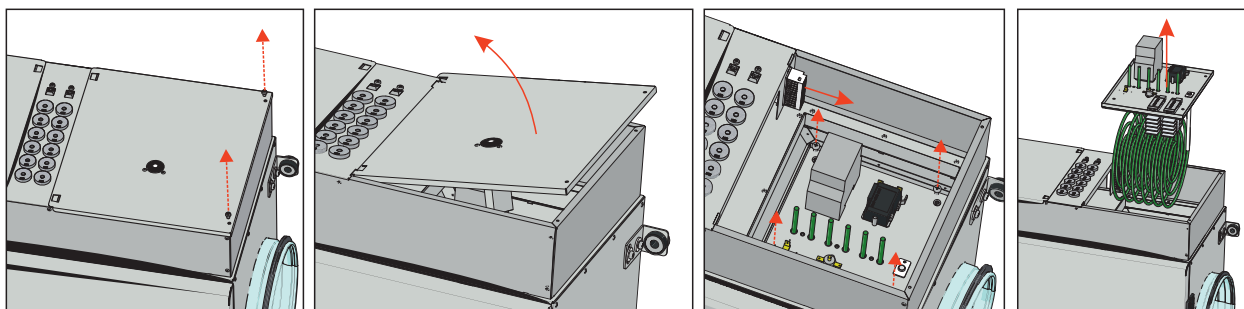

6.8. CONTROL BOARD MAINTENANCE

- Disconnect product unit from electric power source.
- Unscrew the bolts on the control box.
- Remove the control box cover.
- Disconnect all cables, wires, and connectors from the control board and unscrew the control board mounting bolts.
- Remove control board.
- To reassemble, follow all maintenance steps in reverse order. When re-connecting cables, wires, and connectors, make sure to match each wire and connector to corresponding connection terminal and connector.

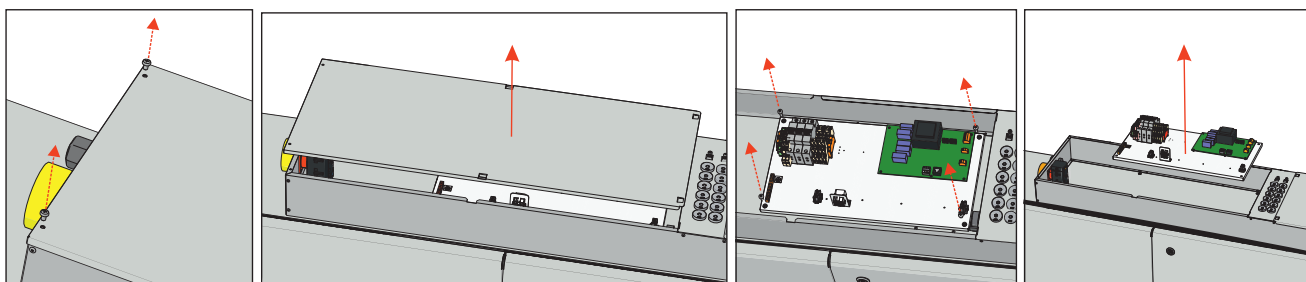

7. CONTROL

7.1. DEVICE CONTROL

Ventilation unit equipped with PRV control board can be controlled with remote controller, WEB interface or mobile app via MB-GATEWAY and BMS (building management system). More information provided in the table below.

With MB-GATEWAY	Remote control panels	BMS direct connection	Wireless communication
Web interface	Stouch	Modbus RTU (RS485)	MB-GATEWAY + WIFI router
SALDA AIR mobile application	ST-SA-Control		
BMS over Modbus TCP/IP	FLEX		
BMS over BACnet TCP/IP			

7.2. DEVICE FUNCTIONS

PRV control board operation functions and control of the device depends on the following:

1. Selected control interface (remote control panel, MB-GATEWAY, etc.). The selected interface affects access to the information and settings, however, it does not affect the logic of control. Full access to the information and settings is available on FLEX, ST-SA-Control, MB-GATEWAY WEB application and SALDA AIR mobile application.
2. Unit configuration (internal/external components, sensors and control board settings).



Refer to the instruction manual of the existing control device for unit control instructions.

8.4. CO2 CONCENTRATION ACCORDING TO PETTENKOFER LIMIT

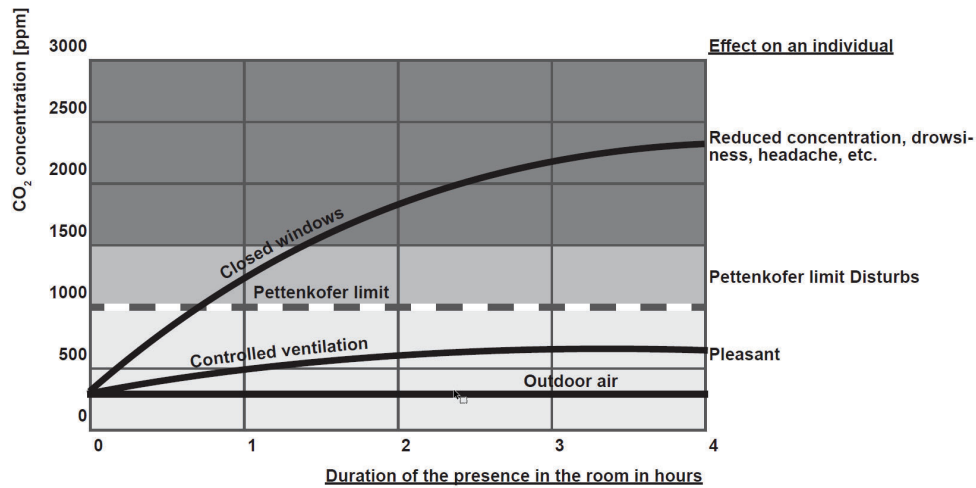

8.5. CONNECTION OF SUPPLY AND EXTRACT AIR DAMPERS

Product RIS P EKO 3.0 can be equipped with supply air and extract air dampers. Dampers are controlled by Open/Close or Spring-return actuators.

Wiring diagram for RIS PE EKO 3.0

M2, M3 – Open/Close damper actuators. Upon activation of outputs X16:17, X16:20 the dampers shall open, Upon activation of outputs X16:16, X16:19 the dampers shall close.

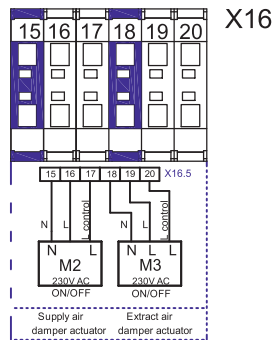

Wiring diagram for RIS PW EKO 3.0

M2 – Spring-return damper actuator. M3 – Open/Close damper actuator. Upon activation of outputs X16:17, X16:20, the dampers open, Upon activation of output X16:19, the extract air damper close. The supply air damper is controlled by spring-return actuator so that when output X16:16 is deactivated, the supply air damper closes.

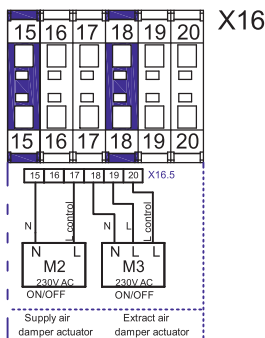

8.6. CONNECTION OF REMOTE CONTROL PANEL OR MODBUS

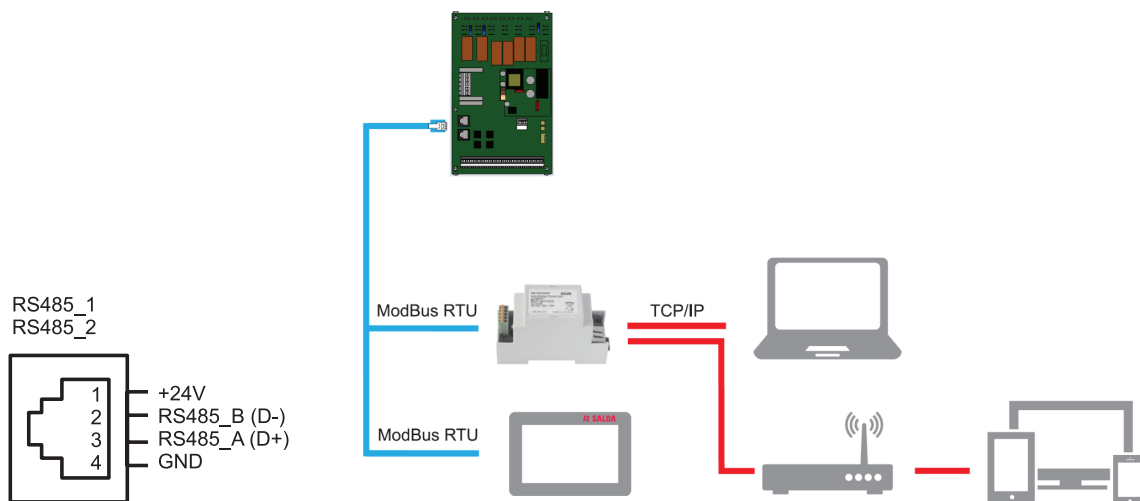

8.7. WATER HEATER CIRCULATION PUMP AND VALVE ACTUATOR

Water heater circulation pump and valve actuator can only be connected to the units that are designed to operate with water heater (RIS PW EKO 3.0 units).

Wiring diagram

Valve actuator is controlled by 0-10 VDC signal. Circulation pump is controlled by On/Off signal.

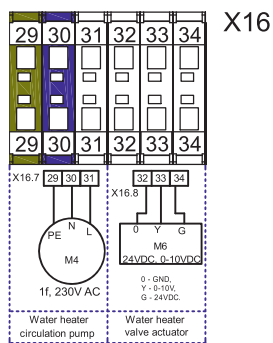

- PV - supply air fan EC.
- IV - extract air fan EC.
- TL - fresh air temperature sensor.
- TJ - supply air temperature sensor.
- DTJ100 - extract air temperature and humidity sensor.
- TE - exhaust air temperature sensor.
- TV - Water heater antifreeze return heat carrier temperature sensor.
- T1 - Water heater antifreeze thermostat.
- M1 - BYPASS damper actuator.
- M2 - outside air damper actuator.
- M3 - extract air damper actuator.
- M4 - Water heater circulatory pump.
- M5 - water cooler valve actuator.
- M6 - Water heater valve actuator.
- P - DX cooler protection, differential pressure switch.
- P/U - "Transmitter 1" supply air pressure transmitter (0-10 VDC).
- P/U - "Transmitter 2" extract air fan 0-10V pressure, CO2 transmitters.
- FA - fire alarms input.
- PS1 - supply air filter pressure relay.
- RG1 - controller PRV... VZ.5.
- Q1 - disconnect.
- F1, F2 - fuses (size BT-5x20).

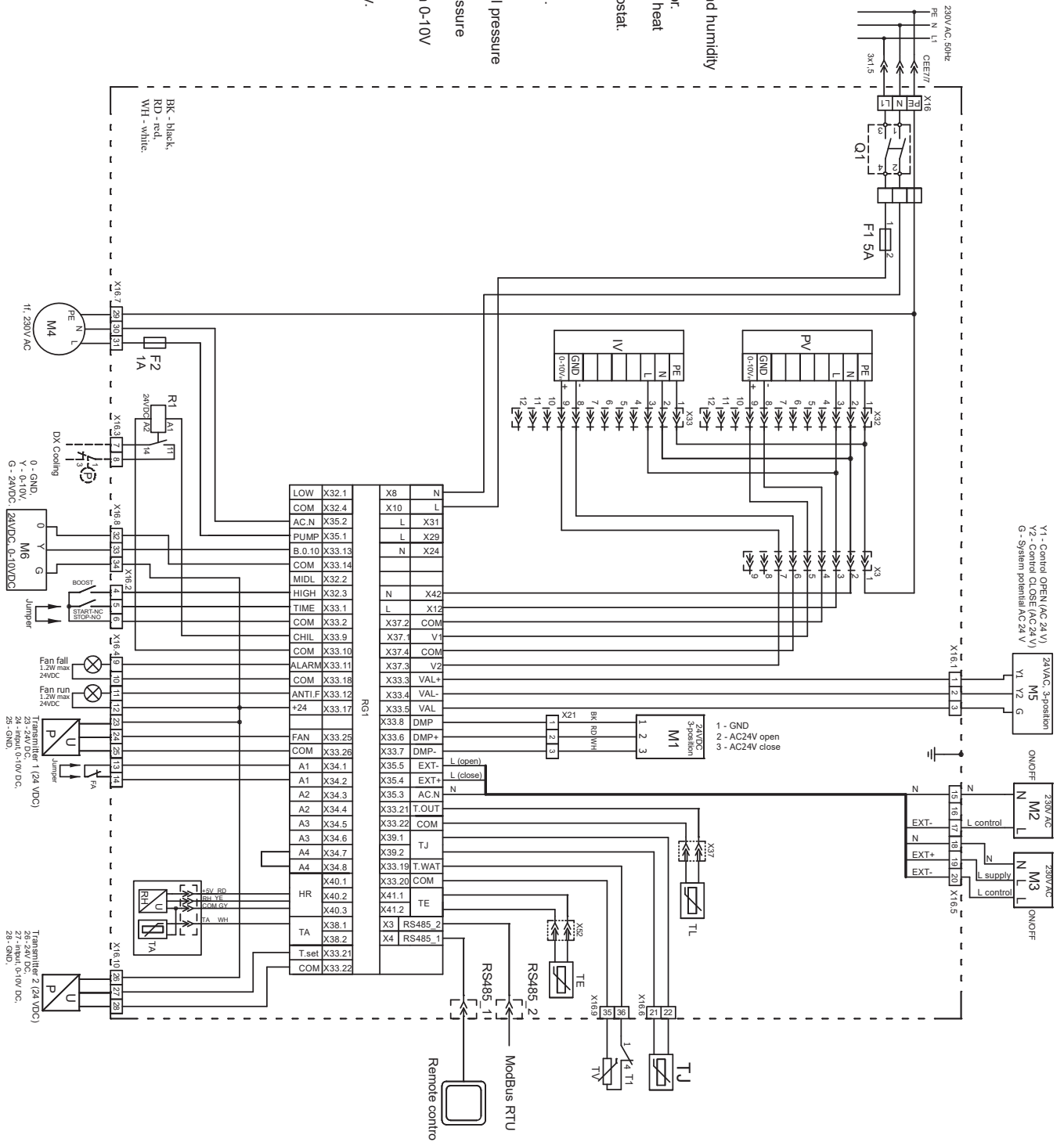
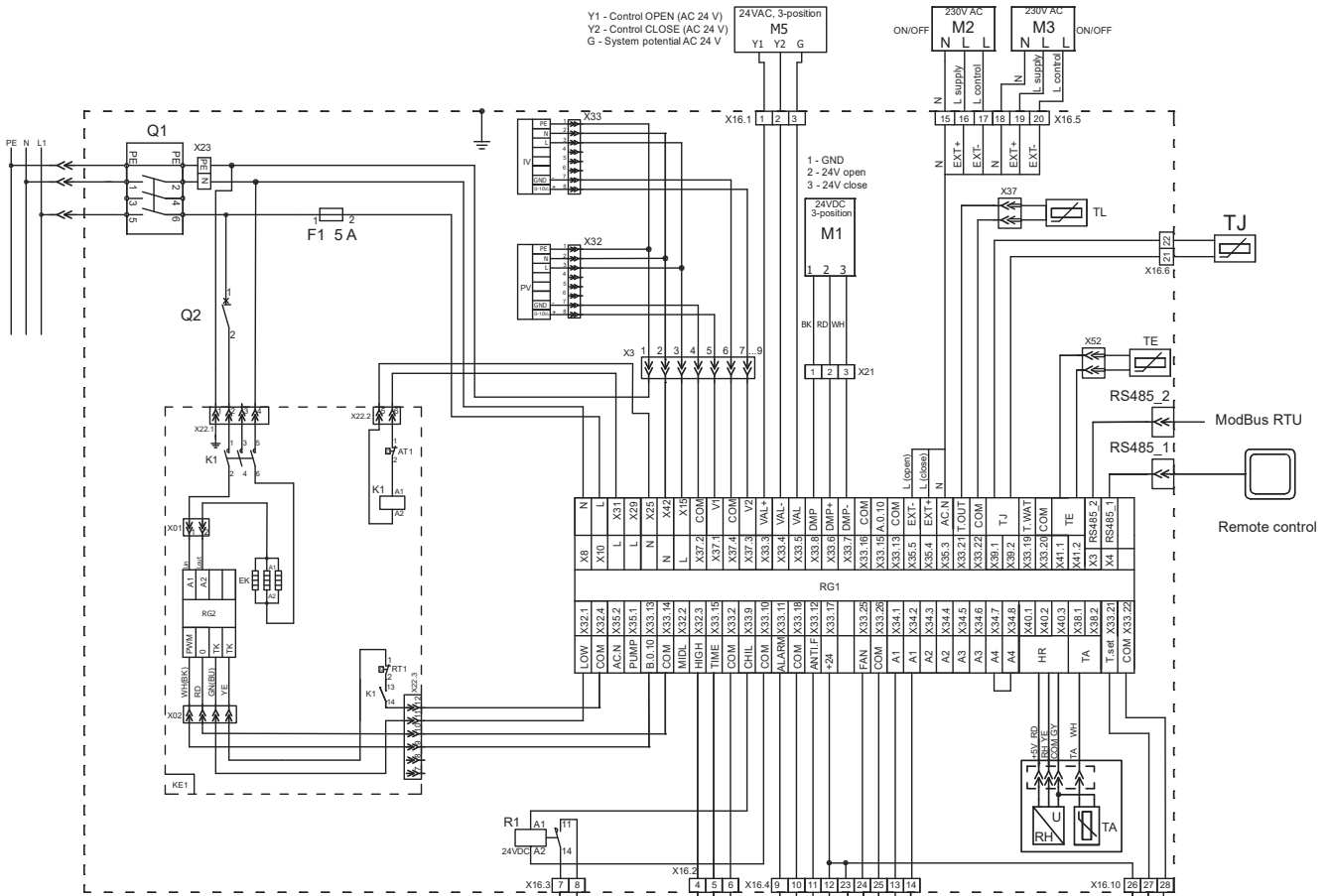

Figure 8.8.2. RIS 400/700 PW EKO 3.0



Color markings:
 WH(BK) - White(Black)
 RD - Red
 GN(BU) - Green (Blue)
 YE - Yellow

- PV - supply air fan EC.
- IV - extract air fan EC.
- KE1 - supply air heater.
- AT1 - automatic reset thermostat supply air heater.
- RT1 - manual reset thermostat supply air heater.
- TL - outside air temperature sensor.
- TJ - supply air temperature sensor.
- TE - exhaust air temperature sensor.
- DTJ100 - extract air humidity + temperature sensor.
- M1 - BYPASS damper actuator.
- M2 - outside air damper actuator.
- M3 - extract air damper actuator.
- M5 - water cooler valve actuator.
- FA - fire alarm input.
- P/U - "Transmitter 1" supply air fan pressure transmitter (0-10 VDC).
- P/U - "Transmitter 2" extract air fan pressure, CO2 transmitters (0-10 VDC).

- P - DX cooler protection, differential pressure switch.
- KE1 - electrical heater 3,0kW/230V, 1f.
- RG1 - PRV-V2.5.
- RG2, RG3 - controllers ESKM1-26/176-30.
- Q1 - disconnector.
- Q2 - circuit breakers.
- F1 - fuse (size 5x20)

Figure 8.8.3. RIS 700 PE 1,2/3,0 EKO 3.0

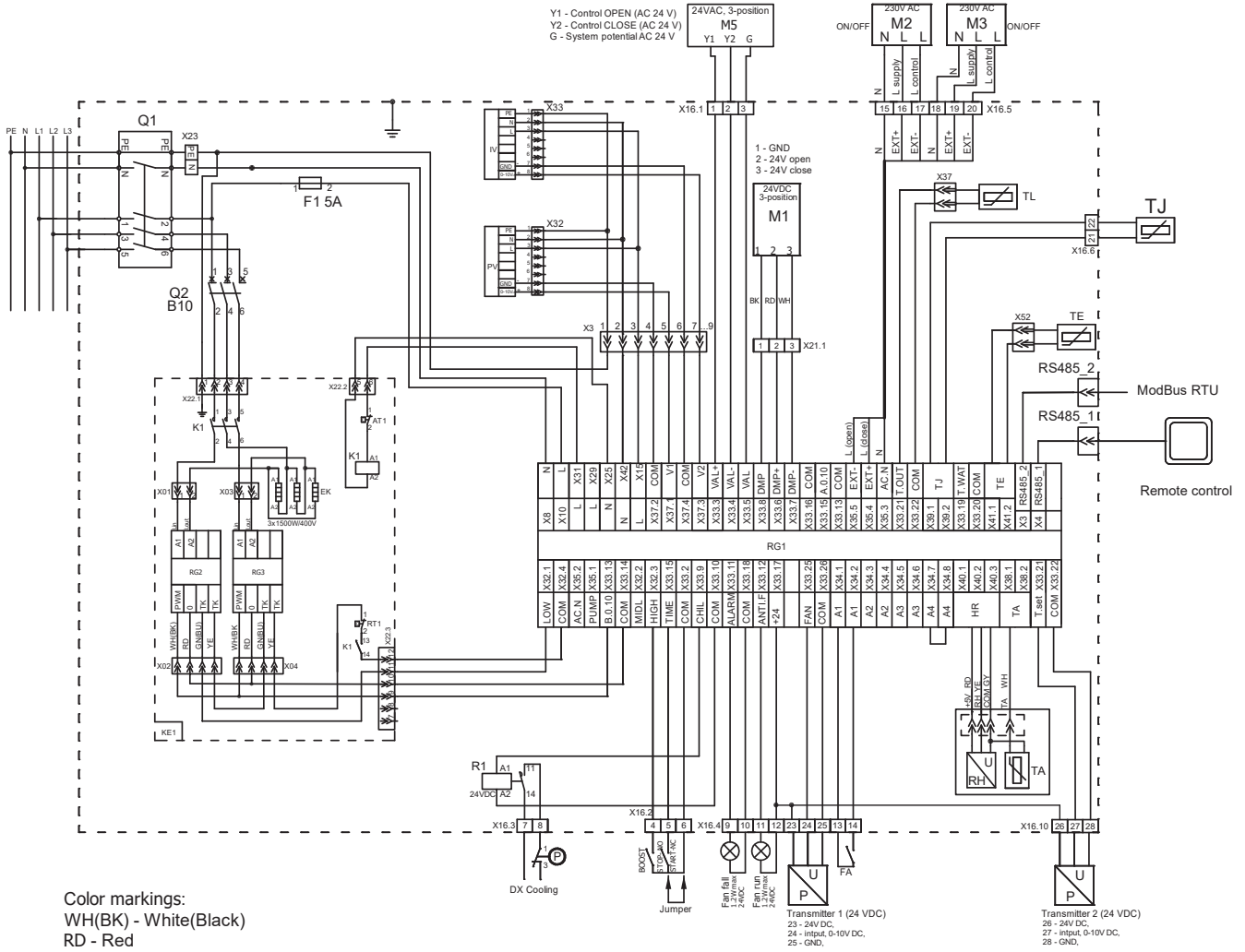

Color markings:
 WH(BK) - White(Black)
 RD - Red
 GN(BU) - Green (Blue)
 YE - Yellow

- PV - supply air fan EC.
- IV - extract air fan EC.
- KE1 - supply air heater.
- AT1 - automatic reset thermostat supply air heater.
- RT1 - manual reset thermostat supply air heater.
- TL - outside air temperature sensor.
- TJ - supply air temperature sensor.
- TE - exhaust air temperature sensor.
- DTJ100 - extract air humidity + temperature sensor.
- M1 - BYPASS damper actuator.
- M2 - outside air damper actuator.
- M3 - extract air damper actuator.
- M5 - water cooler valve actuator.
- FA - fire alarm input.
- P/U - "Transmitter 1" supply air fan pressure transmitter (0-10 VDC).
- P/U - "Transmitter 2" extract air fan pressure, CO2 transmitters (0-10 VDC).

- P - DX cooler protection, differential pressure switch.
- KE1 - electrical heater 4,5kW/400V, 3f.
- RG1 - PRV-V2.5.
- RG2, RG3 - controllers ESKM1-26/176-30.
- Q1 - disconnector.
- Q2 - circuit breakers.
- F1 - fuse (size 5x20)

Figure 8.8.4. RIS 700 PE 4,5 EKO 3.0

9. POSSIBLE FAULTS AND TROUBLESHOOTING

FAILURE	CAUSE	EXPLANATION / CORRECTIVE ACTIONS
Unit is not operating	No supply voltage	Check whether the device is connected to the power network
	Protection device is off or a current leakage relay is active (if installed by the installer)	Switch on only if the unit condition has been evaluated by a qualified electrician. If the system failed, the failure MUST BE rectified prior to switching it on.
Air supply heater or pre-heater is not operating or malfunctioning (if installed)	Too low air flow in air ducts activates automatic protection	Check if air filters are not clogged Check if fans are rotating
	Manual protection is activated	Possible heater or unit failure. MUST contact the servicing staff for failure detection and its elimination.
Too low air flow at rated fan speed	Clogged supply and/or extract air filter(s)	Filter replacement needed
Filters are clogged and no message is shown on the remote control	Wrong time in filter timers or their switch is broken, or its pressure is set improperly.	Shorten filter timer time to the message of clogged filters or replace the pressure switch of the filters, or set their proper pressure.

10.ECODESIGN DATA TABLE

MODEL			RIS 400 PE/PW EKO 3.0			
Climate zone	Control typology	Control factor	Specific energy consumption (SEC)	SEC Class	AEC	AHS
			[kWh/m ² /a]			
Average	Central demand control (standard with 1 sensor)	0,85	-38,4	A	253	4410
	Local demand control (opt. with 2 sensors)	0,65	-41,8	A	167	4526
Cold	Central demand control (standard with 1 sensor)	0,85	-75,3	A+	790	8628
	Local demand control (opt. with 2 sensors)	0,65	-79,7	A+	704	8853
Warm	Central demand control (standard with 1 sensor)	0,85	-14,7	E	208	1994
	Local demand control (opt. with 2 sensors)	0,65	-17,4	E	122	2046
Declared typology			Bidirectional			
Type of drive installed (fan)			Variable			
Type of heat recovery system			recuperative			
Thermal efficiency of heat recovery		[%]	81,9			
Maximum flow rate		[m ³ /h]	393			
Electric power input of the fan drive at maximum flow rate		[W]	155			
Sound power level (Lwa)		[dB(A)]	50			
Reference flow		[m ³ /s]	0,076			
Reference pressure difference		[Pa]	50			
SPI		[W/(m ³ /h)]	0,23			
Declared maximum internal leakage rates		[%]	1,2			
Declared maximum external leakage rates		[%]	1,2			
Position and description of visual filter warning for RVU's			Timer			
ErP Compliance			2018			
Internet address for disassembly instructions			www.salda.it			

MODEL			RIS 700 PE/PW EKO 3.0			
Climate zone	Control typology	Control factor	Specific energy consumption (SEC)	SEC Class	AEC	AHS
			[kWh/m ² /a]			
Average	Central demand control (standard with 1 sensor)	0,85	-37,7	A	280	4402
	Local demand control (opt. with 2 sensors)	0,65	-41,3	A	183	4519
Cold	Central demand control (standard with 1 sensor)	0,85	74,4	A+	817	8612
	Local demand control (opt. with 2 sensors)	0,65	-79,2	A+	720	8841
Warm	Central demand control (standard with 1 sensor)	0,85	-14,0	E	235	1991
	Local demand control (opt. with 2 sensors)	0,65	-17,0	E	138	2044
Declared typology			Bidirectional			
Type of drive installed (fan)			Variable			
Type of heat recovery system			recuperative			
Thermal efficiency of heat recovery		[%]	81,6			
Maximum flow rate		[m ³ /h]	700			
Electric power input of the fan drive at maximum flow rate		[W]	340			
Sound power level (Lwa)		[dB(A)]	50			
Reference flow		[m ³ /s]	0,136			
Reference pressure difference		[Pa]	50			
SPI		[W/(m ³ /h)]	0,26			
Declared maximum internal leakage rates		[%]	1,1			
Declared maximum external leakage rates		[%]	1,7			
Position and description of visual filter warning for RVU's			Timer			
ErP Compliance			2018			
Internet address for disassembly instructions			www.salda.it			

11. DECLARATION OF CONFIRMITY

Manufacturer

SALDA, UAB
Ragainės g. 100
LT-78109 Šiauliai, Lithuania
Tel.: +370 41 540415
www.salda.lt

Hereby confirms that the following products - Air handling units:

RIS * EKO 3.0

(where by „*“ indicates possible unit installation type and modification)

Provided it was delivered and installed in the facility in accordance with the included installation instructions, comply with all applicable requirements in the following directives:

Machinery Directive 2006/42/EC
EMC Directive 2014/30/EU
Low Voltage Directive 2014/35/EU
Ecodesign Directive 2009/125/EC
RoHS 2 Directive 2011/65/EU

The following regulations are applied in applicable parts:

Ecodesign requirements for ventilation units Nr. 1253/2014
Energy labeling of residential units Nr. 1254/2014

The following harmonized standards are applied in applicable parts:

LST EN 13141-7:2011 - Ventilation for buildings - Performance testing of components/products for residential ventilation - Part 7: Performance testing of a mechanical supply and exhaust ventilation units (including heat recovery) for mechanical ventilation systems intended for single family dwellings.

LST EN ISO 12100:2011 - Safety of machinery - General principles for design - Risk assessment and risk reduction.

LST EN 60204-1:2018 - Safety of machinery - Electrical equipment of machines - Part 1: General requirements.

LST EN 60335-1:2012 - Household and similar electrical appliances. Safety. Part 1: General requirements.

LST EN 60529:1999/A2:2014/AC:2019 - Degrees of protection provided by enclosures (IP code).

LST EN 61000-6-1:2007 - Electromagnetic compatibility (EMC) .Part 6-1: Generic standards - Immunity for residential, commercial and light-industrial environments.

LST EN 61000-6-4:2007/A11:2011 - Electromagnetic compatibility (EMC) .Part 6-4: Generic standards - Emission standard for industrial environments.

Should any alterations be made in the products, this declaration will no longer apply.

Quality: SALDA UAB activities are in line with the international quality management system standard **ISO 9001:2015**.

Date 2022-05-17



Giedrius Taujenis
Product Manager

12. WARRANTY

1. All equipment manufactured in our factory is checked in operating conditions and tested before delivery. Test protocol is supplied together with the unit. The equipment is shipped in good working condition to the end-client. The unit is warranted for the period of two years from the invoice date.
2. If equipment is found to have been damaged during transportation, a claim should be made against carrier, as we assume no responsibility for such damage.
3. This warranty does not apply:
 - 3.1. when transportation, storage, installation and maintenance instructions of the unit are violated;
 - 3.2. when the equipment is improperly maintained, mounted - inadequate maintenance;
 - 3.3. when the equipment without our knowledge and permission has been upgraded or unskilled repairs were made;
 - 3.4. when the unit was used not for its original purpose.
 - 3.5. Company SALDA UAB is not responsible for potential loss of property or personal injury in cases where AHU is manufactured without a control system and the control system will be installed by the client or third parties. The manufacturer's warranty does not cover devices that will be damaged by installing the control system.
4. This warranty does not apply at these malfunction cases:
 - 4.1. mechanical damage;
 - 4.2. damage caused by entering outside objects, materials, liquids;
 - 4.3. damage caused by natural disaster, accident (voltage change in the electricity network, lightning, etc..).
5. The company assumes no liability for its products either directly or indirectly damage, if the damage is caused by failure to comply with installation and mounting regulations, deliberate or careless users or third-party behavior.

These conditions are readily discernable when the equipment is returned to our factory for inspection.

If the direct client determines that equipment is found to be faulty, or a breakdown occurred, he should inform the manufacturer within five working days and deliver the equipment to manufacturer. Delivery costs should be covered by customer.



Manufacturer reserves the right to change this technical passport any time without prior notice, if some typographic errors or inaccurate information is found, as well as after improving the apps and/or the devices. Such changes will be included in the new issues of the technical passport. All illustrations are just for information and thus may differ from the original device.

12.1. LIMITED WARRANTY COUPON

Warranty term

24 months*

I received complete package and technical manual of the product ready for use. I have read and agreed with the warranty terms and conditions:

.....
Customer's signature

*refer to WARRANTY CONDITIONS

Dear User, we appreciate your choice and do hereby guarantee that all ventilation equipment manufactured by our Company is inspected and thoroughly tested. An operational and high-quality product is sold to the direct buyer and shipped from the territory of the factory. It is provided with a 24-month warranty since invoice issue date.

Your opinion is important to us, thus we always look forward to hearing your comments, feedback, or suggestions regarding technical and operational characteristics of the Products.

In order to avoid any misunderstandings, please read the instructions for installation and operation of the product as well as other technical documents of the product carefully. The number of the Limited Warranty Coupon and serial number of the product specified on the silver identification sticker attached to the housing must match.

The Limited Warranty Coupon shall be valid provided that the seller's stamps and records are clear. It is not allowed to change, delete, or rewrite the data specified on it in any manner – such a coupon shall be invalid.

With this Limited Warranty Coupon the manufacturer confirms one's obligations to implement the imperative requirements established by effective laws on protection of consumer rights in the event of identification of any defects of the products.

The manufacturer reserves the right to refuse provision of free warranty servicing in cases when the warranty conditions listed below are disregarded.

PRODUCT MAINTENANCE TABLE

Product name*		
SERIAL number*		
installation	interval	Date
Fan cleaning	Once per year**	_____
Heat-exchanger cleaning	Once per year**	_____

Filter replacement	Every 3-4 months**	_____

* - Look at the product label.
 ** - At least.

NOTE. The customer shall be required to complete the Product Maintenance Table.

MANUALS IN OTHER LANGUAGES

DE	DK	FR	IT	LT
				
https://select.salda.lt/file/ris400-700pekode	https://select.salda.lt/file/ris400-700pekodk	https://select.salda.lt/file/ris400-700pekofr	https://select.salda.lt/file/ris400-700pekoit	https://select.salda.lt/file/ris400-700pekolt
NL	PL	RU		
				
https://select.salda.lt/file/ris400-700pekonl	https://select.salda.lt/file/ris400-700pekopl	https://select.salda.lt/file/ris400-700pekoru		

